

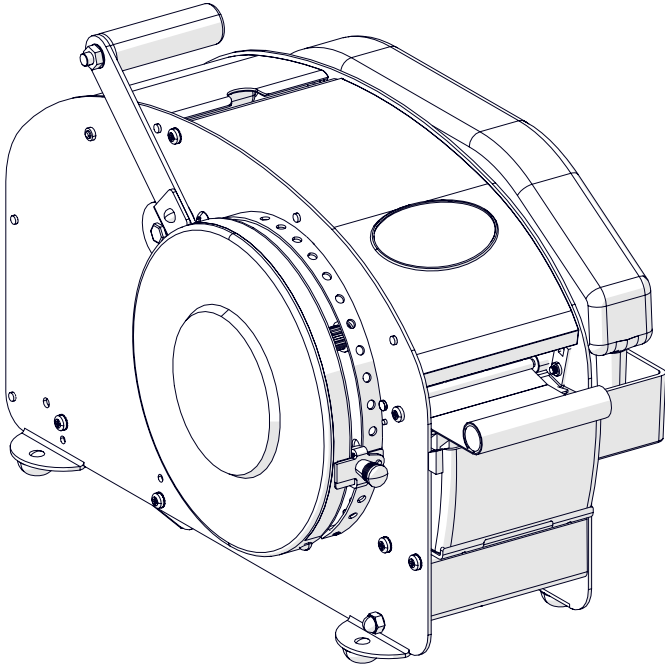

**BETTER
PACKAGES[®], Inc.**
A WHOLLY OWNED SUBSIDIARY OF 

USER MANUAL 333 PLUS SERIES



**BETTER
PACKAGES[®], Inc.**
A WHOLLY OWNED SUBSIDIARY OF 

**BETTER
PACKAGES[®], Inc.**
A WHOLLY OWNED SUBSIDIARY OF 

USER NOTES

TABLE OF CONTENTS

Technical Assistance	4
Replacement Parts	4
Warranty Information	5
Warranty Information	6
Warranty Registration	6
General Information	7
Description of the 333 Plus	7
Definitions	7
Optional Equipment	8
Heater	8
Important Safeguards	9
Label Placement	10
Label Descriptions	11
Machine Nameplate	12
Important Safeguards	13
Explanation of Signal Word Consequences	13
Operator Skill Level Descriptions	14
Specifications	15
333 Plus Dimensions	15
333 Plus Components	16
Operating Conditions	17
Tape Requirements	17
Technical Specifications	17
Set-up Procedure	18
Unpacking	18
Verifying the Contents	18
Adjusting the Roll Guides	18
Loading the Tape Gum Side In	19
Checking the Upper Tape Plate	20
Installing the Brushes and Water Tank	21
Water Tank Install	22
Water Bottle Install	23
Operation	24
General Operating Procedures	24
Selecting the Length of Tape	24
Dispensing Tape	24
Applying Tape to a Carton	25
Choosing the Correct Tape Type	25
Choosing the Correct Tape Length	25
Proper Tape Moistening	25
Applying Tape to a Carton	26
Sealing the Carton	26
Common Tape Patterns	26
Preventative Maintenance	27
Suggested Preventative Maintenance Schedule	27
Washing the Tank, Brush, and Bottle	27
Troubleshooting	28
Spring Identification	29
Appendix	30

TECHNICAL ASSISTANCE

This is the Better Packages Model **333 Plus Series** WAT Tape Dispenser you ordered. It has been set up and tested in our factory with IPG manufactured water activated tapes. If any problems occur when setting up or operating this equipment, please contact the authorized distributor from where you purchased this item.

If contact with the authorized distributor is not possible, **IPG Machinery Support** is available. Should the need to contact **IPG Machinery Support** arise, **please have the equipment model and serial number available prior to contact**. This information can be found on the nameplate of the Dispenser. A section at the bottom of this page is available to write this information down. **IPG Machinery Support** is available during normal business hours (M-F 8am-7pm) Eastern Time.

Phone: +1 813-345-3070

Email: machsupp@itape.com

Replacement Parts

A breakdown of parts, including part numbers, can be provided upon request. If you know the part number that you require please contact your authorized distributor or Better Packages Customer Service 1-203-926-3700 or 1-800-237-9151 (United States only), parts can also be found directly at www.betterpackages.com/parts

Please use this area to enter the detailed information on your dispenser. This should be filled out at the time of install. This information can be found on the nameplate of the machine, next to the main power plug on the back of the dispenser.

Machine

Model

Serial

Distributor

Name

Phone/Email

Date of Purchase

WARRANTY INFORMATION

Better Packages, Inc. Limited Warranty

Better Packages warrants each new machine and accessory to be free from defects in materials and workmanship under normal and proper use conditions. The following warranty periods from date of purchase apply:

Model	Parts	Labor
Better Pack 755e Series	2 Years	6 Months
Better Pack 555e Series	2 Years	6 Months
Better Pack 500 Series	2 Years	6 Months
Better Pack 333 Series	2 Years	6 Months
Curby Mini Taper (BP222)	1 Year	6 Months
Packer 3S	2 Years	6 Months
Tape Shooter 404	2 Years	6 Months
Auto H2O Series	1 Year	6 Months

Wearable parts such as shear blades, water brushes, motor brushes, **side guide plates and upper tape guide plates** are not covered under the warranty. The following wearable parts are warranted for 3 months from date of purchase:

1. Main Board
2. Solenoid
3. Main Motor

Warranty Conditions and Exclusions

Machines and accessories used for any improper or unintended purpose will not be considered for warranty protection. Any modification of the machines or accessories shall make this warranty null and void. Use of replacement parts other than genuine Better Packages replacement parts shall also make this warranty null and void.

Better Packages shall have no obligation to repair or replace (1) those parts failing due to operator misuse, carelessness, or due to any accidental cause other than equipment failure, or (2) parts that fail due to:

1. Misapplication, lack of proper maintenance, abuse, improper installation, or abnormal conditions such as temperature, moisture, dirt, or corrosive matter, etc.
2. Inadequate cleaning, improper operating environment, improper utilities, or operator error.
3. Operations beyond the rated capacity of the product.
4. Alteration or servicing of the product by anyone other than an authorized representative of Better Packages.
5. Any attempt by the purchaser to repair or correct alleged defective equipment. In this event the purchaser is responsible for all expenses incurred.

IN NO EVENT SHALL BETTER PACKAGES BE LIABLE FOR ANY INDIRECT, INCIDENTAL OR CONSEQUENTIAL DAMAGE FROM THE SALE OR USE OF THESE PRODUCTS. THIS DISCLAIMER APPLIES BOTH DURING AND AFTER THE TERM OF WARRANTY.

THIS WARRANTY IS EXPRESSLY IN LIEU OF ALL OTHER WARRANTIES, EXPRESS OR IMPLIED, INCLUDING THE WARRANTIES OF MERCHANTABILITY AND FITNESS FOR A PARTICULAR PURPOSE (EXCEPT AS MAY BE OTHERWISE PROVIDED BY LAW).

This warranty gives you specific legal rights, and you may also have other rights, which vary, from state to state.

WARRANTY INFORMATION

Warranty Service

Better Packages will replace or repair (at the company's discretion) any defective parts within the warranty period, on a no-charge basis. The Authorized Distributor/Service Center will furnish, without charge, necessary labor to service the machine.

For service under this warranty, call or write your nearest Better Packages Distributor/Service Center or Better Packages, Inc. Ansonia, CT at 800-237-9151 (US only) or (203) 926-3700.

If customer wishes, with authorization from Better Packages or an Authorized Distributor/Service Center, a product may be shipped to Better Packages for warranty service. Any item shipped for warranty service must be shipped in the original factory carton and properly packed with the original protective packaging inserts or a secure carton that will properly protect the unit during transit. Any damage to machines or parts received improperly packed are the responsibility of the customer. All associated shipping or freight costs related to items shipped for service are the sole responsibility of the customer. Transportation charges on machines or parts returned to Better Packages for service must be prepaid by the customer. Customers will be responsible for freight expenses on parts or machines returned to them.

Better Packages' ship-to address is: 4 Hershey Drive, Ansonia, Connecticut 06401.

Warranty Registration

Filling out the warranty card and returning it to us protects your warranty and allows us to keep you informed of product upgrades. Visit www.betterpackages.com/warranty-registration to fill out the warranty card online.

GENERAL INFORMATION

Description of the 333 Plus

The Better Packages 333 Plus Series is water-activated tape dispenser (also known as a paper tape dispenser, gummed, or gum tape water-activated tape dispenser) and comes standard with a large capacity tape basket. The 333 Plus series is designed for medium to high volume shipping and packaging areas. This allows for up to a 600 ft. long or 7.75" diameter roll of tape (305 meter long or 182.8mm diameter roll).

The 333 Plus is a fully manual dispenser that does not require any electrical power. This dispenser is ideal for pack stations that are set up a distance from any power source and comes standard with a high capacity water bottle, 46oz (1.3 liter).

The 333 Plus can be equipped with an optional heater unit. Consult IPG Machinery Support if you believe you need this heater unit.

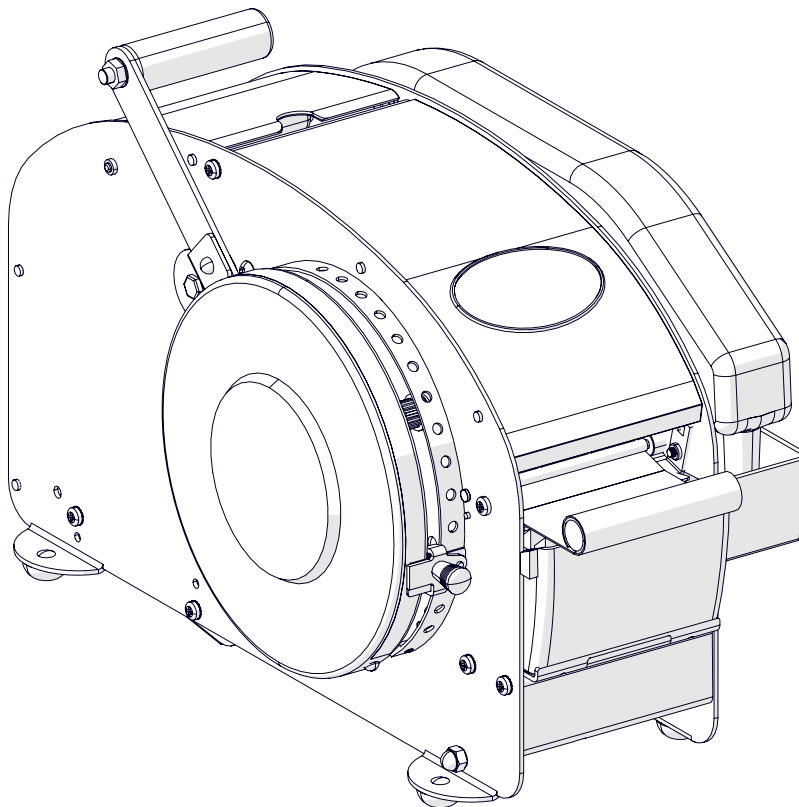

Figure 1: Better Packages 555e

Definitions

Common terms that will be used throughout this manual.

WAT – IPG Brand Water Activated Tape

User/Operator – The individual who has been trained on the daily use of the Machine System

Maintenance Champion – The individual(s) who work for the end user of the Machine System who are responsible for conducting general and preventative maintenance

OPTIONAL EQUIPMENT

Heater

The Better Packages 333 Plus can be equipped with an optional heater (order number [TH55PXXXK](#)). It is recommended to use the heater in cooler environments where the water will be less than 50° F (10° C). While not necessary for normal operation the use of warmer water will activate the adhesive sooner. Allowing for a faster application.

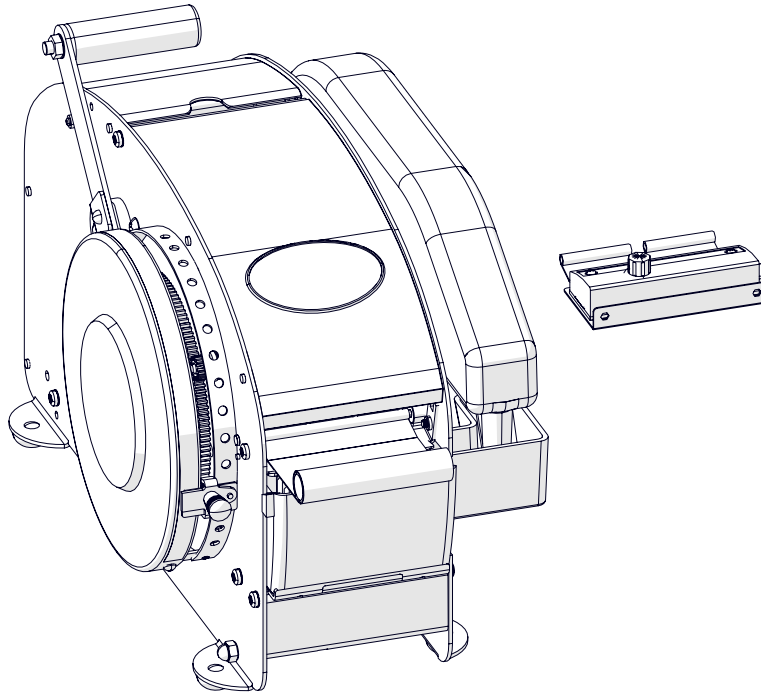

The heater replaces the weighted tape plate.

Electrical Requirements: 110V 60Hz, 4A

When using the heater always plug it into a properly grounded outlet and lift the heater from the attached handle.



CAUTION: UNDER NORMAL OPERATIONAL CONDITIONS THE BOTTOM OF THE HEATER WILL BE HOT. HANDLE THE HEATER ONLY USING THE TABS ON EITHER SIDE OF THE HEATER OR ALLOW TIME FOR THEM TO FULLY COOL BEFORE HANDLING.

Code Taper

The Code Taper custom prints one color messages directly onto the water-activated tape as it is dispensed.

Applications:

Print logos, dates and printed codes on demand. Requires custom roll pads and ink.

IMPORTANT SAFEGUARDS

There are a number of safety labels used on the 555e. These labels are placed at different locations on the dispenser to warn operators and service personnel of possible dangers. Please read the labels on the machine and the following safety precautions before using the machine.

Read this manual for other important safety operating and service information.

Only trained personnel are to operate machine.

Only fully qualified technicians are to service this machine.

Wear safety glasses when performing maintenance.

Allow time to cool before working on the heaters.

Disconnect electrical power before servicing.

Follow Lock Out / Tag Out Procedures BEFORE servicing any machinery.

All factory installed covers and guards must be in place before operating.

Stay clear of moving parts which can shear and cut.

Should any of the safety labels on the dispenser be damaged or destroyed, replacements can be ordered through your distributor.

LABEL PLACEMENT

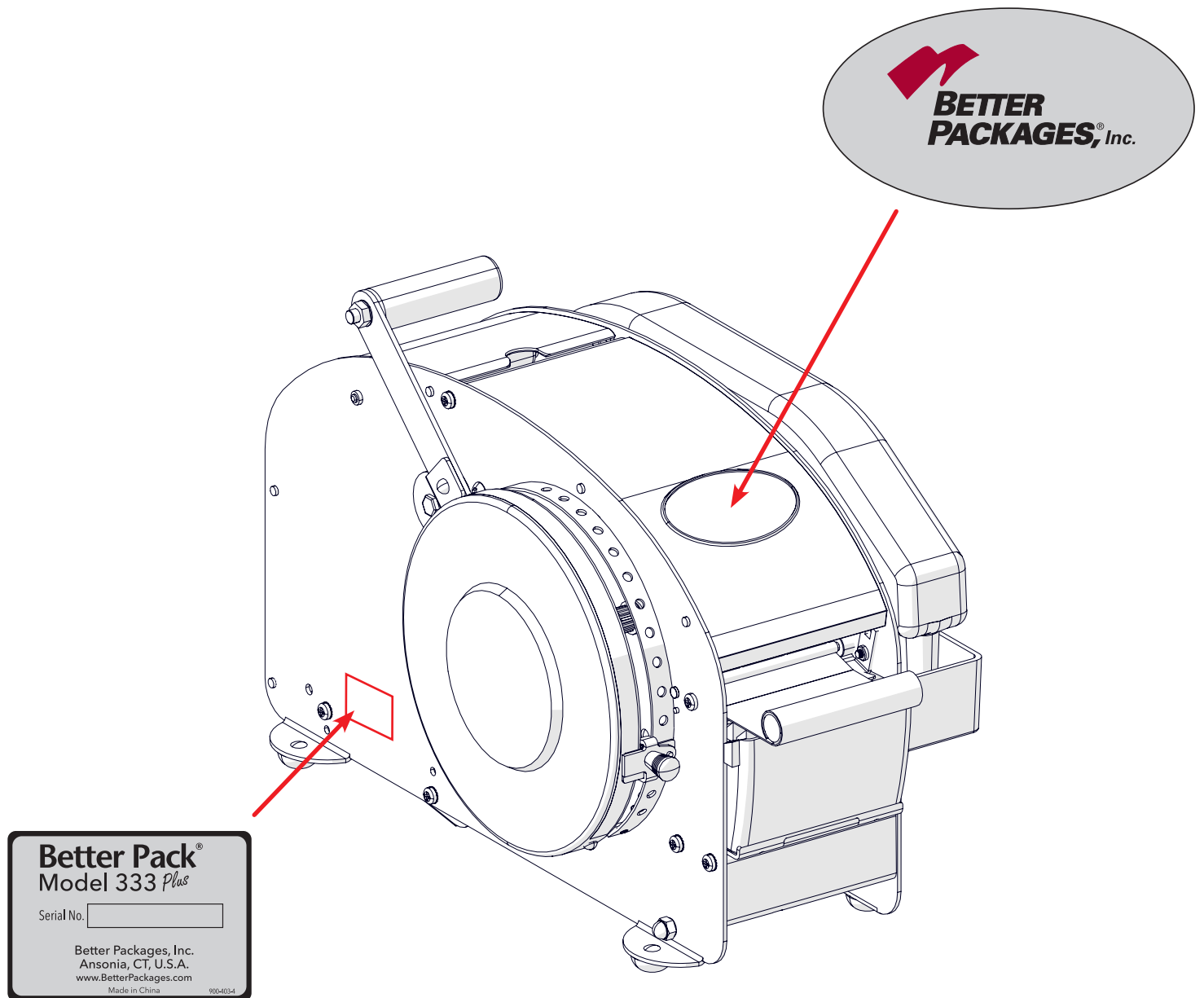

Figure 2: Label Placement

LABEL DESCRIPTIONS

The label shown is affixed to the connection panel on the back of the dispenser.

It is the model and serial label. This will display model, power requirements, serial number, certifications, fuse rating, and manufacturer details.

Reorder number: 9004034 Please contact Better Packages Customer Service for the correct replacement for your machine as there are different models.



Figure 3: Serial Label

The label shown is affixed to the heaters.

It warns operators and service personnel to keep their hands clear of hot elements. Allow time to cool, minimum of 30 minutes, prior to servicing.

Reorder number: 9004050



Figure 4: Dome Decal

Should any of the safety labels on the Case Sealer be damaged or destroyed, replacements can be ordered through your distributor.

MACHINE NAMEPLATE

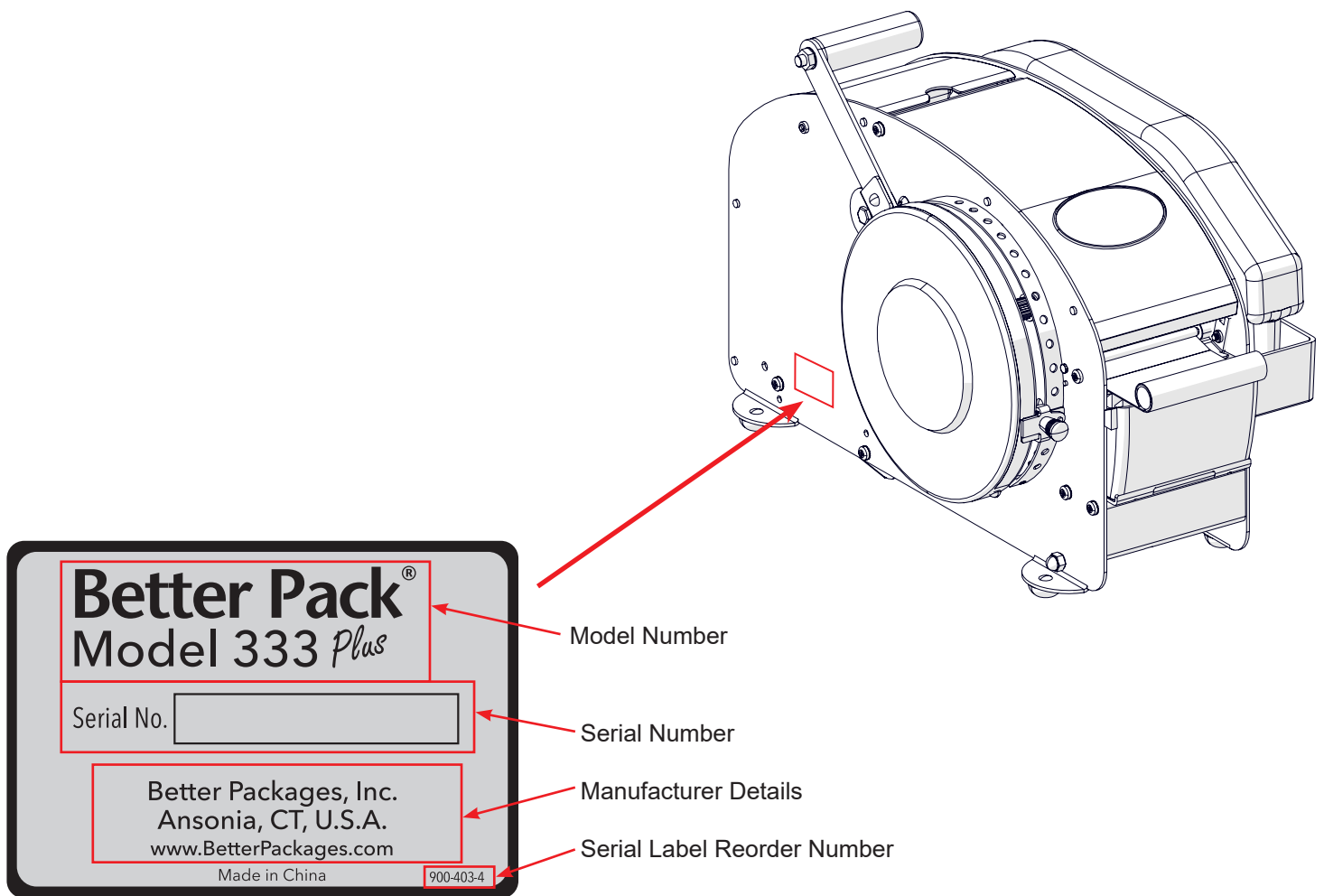

Figure 5: Machine Nameplate

IMPORTANT SAFEGUARDS

Explanation of Signal Word Consequences



WARNING: INDICATES A POTENTIALLY HAZARDOUS SITUATION, WHICH IF NOT AVOIDED COULD RESULT IN DEATH OR SERIOUS INJURY OR PROPERTY DAMAGE



CAUTION: INDICATES A POTENTIALLY HAZARDOUS SITUATION, WHICH IF NOT AVOIDED COULD RESULT IN MINOR OR MODERATE INJURY OR PROPERTY DAMAGE



WARNING

- 1. To reduce the risk associated with mechanical, pneumatic, and electrical hazards:**
 - Read, understand, and follow all safety and operating instructions before operating or servicing the Dispenser
 - Allow only properly trained and qualified personnel to operate and service this equipment
- 2. To reduce the risk associated with pinches, entanglement, and hazardous voltage:**
 - Turn electrical supply off and disconnect before performing any adjustments, maintenance, or servicing the Dispenser
- 3. To reduce the risk associated with pinches and entanglement hazards:**
 - Turn the Dispenser off when not in use
 - Never attempt to work on any part of the Dispenser, load tape, or remove jammed tape from the Dispenser while the machine is powered on
- 4. To reduce the risk associated with hazardous voltage**
 - Position electrical cord away from foot traffic and vehicle traffic
 - Do not operate the Dispenser with a damaged power cord
- 5. To reduce the risk associated with sharp blades hazards:**
 - Keep hand and fingers away from the tape cutoff blades, the blades are very sharp
- 6. To reduce the risk associated with fire and explosion hazards:**
 - Do not operate this equipment in potentially flammable and/or explosive environments
- 7. To reduce the risk associated with muscle strain:**
 - Use proper body mechanics when moving or lifting the Dispenser
- 8. To reduce the risk associated with mechanical, pneumatic, and electrical hazards:**
 - Allow only properly trained and qualified personnel to operate and service this equipment
- 9. Personal Protective Equipment (PPE)**
 - Follow all PPE protocols specific to the facility where the dispenser is installed.



CAUTION

- 1. To reduce the risk associated with pinch hazards:**
 - Keep hands, hair, loose clothing, and jewelry away from internal components



CAUTION: TO AVOID INJURY THE MACHINE OPERATOR SHOULD REMAIN ATTENTIVE AND SHOULD NEVER REST THEIR HANDS, ARMS, HEAD, OR ANY OTHER BODY PART ON THE MACHINE.

This equipment is not suitable for use in locations where children are likely to be present.

IPG manufactured WAT is nonhazardous with no need for first aid measures under recommended/normal use conditions. WAT adhesive can be cleaned with soap and water.

IMPORTANT SAFEGUARDS

Operator Skill Level Descriptions

These descriptions and levels are uniform across all Better Packages WAT Dispensers

Skill “A” Dispenser Operator

This operator is trained to use the Dispenser with the machine controls, to change tape, and to clear jams and perform basic troubleshooting.

Important: *The end user area supervisor must ensure that the operator has been properly trained on all machine functions before operating the machine.*

Skill “B” Mechanical Maintenance Technician

Also referred to as the Maintenance Champion, this technician, is trained to use the Dispenser as the Operator and to check and adjust mechanical components, to perform maintenance operations and repair the Dispenser. A skill “B” operator is not allowed to work on live electrical components.

Skill “C” Factory Trained Technician

A Skill “C” technician is trained by IPG and may perform extraordinary maintenance. This includes any electrical components.

Operators skill level required to perform the following tasks on the 333 Plus

OPERATION	MACHINE CONDITION	OPERATOR SKILL LEVEL	NUMBER OF OPERATORS
Tape Roll Replacement	N/A	A	1
Feed Wheel Adjustment	N/A	A	1
Blade Replacement	Springs Disconnected	B	1
Ordinary Maintenance and Preventative Maintenance	Springs Disconnected	B	1

Better Packages offers a mail in factory maintenance program. Contact your Authorized IPG Representative for more information.

SPECIFICATIONS

333 Plus Dimensions

Dispenser Weight (without tape roll):
22 lbs (10kg)

Maximum tape roll diameter: 7.75in (197mm)
Maximum tape roll length: Up to 600ft (182.8m)

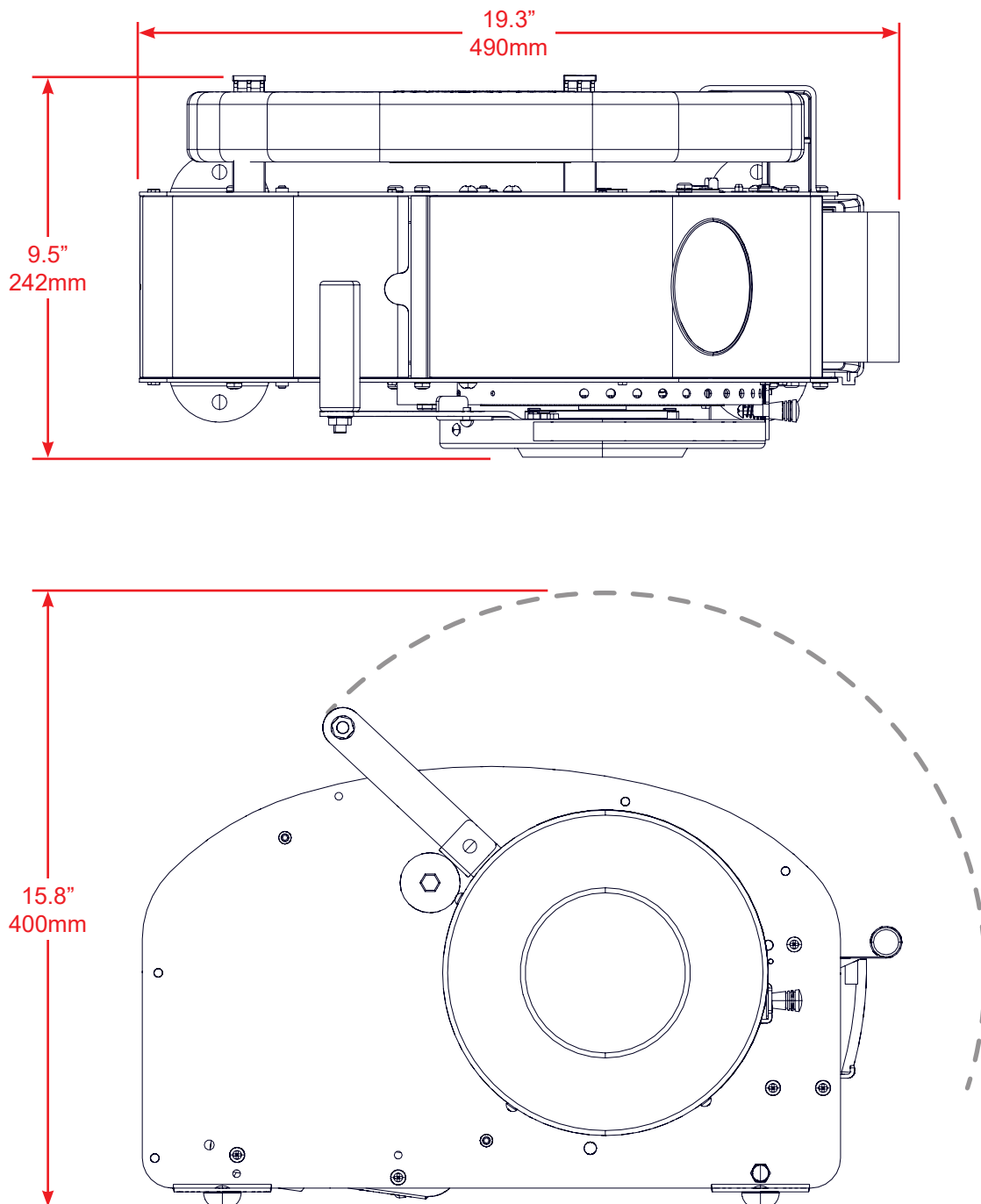

Figure 6: Dispenser Dimensions

SPECIFICATIONS

333 Plus Components

Lids shown in open position.

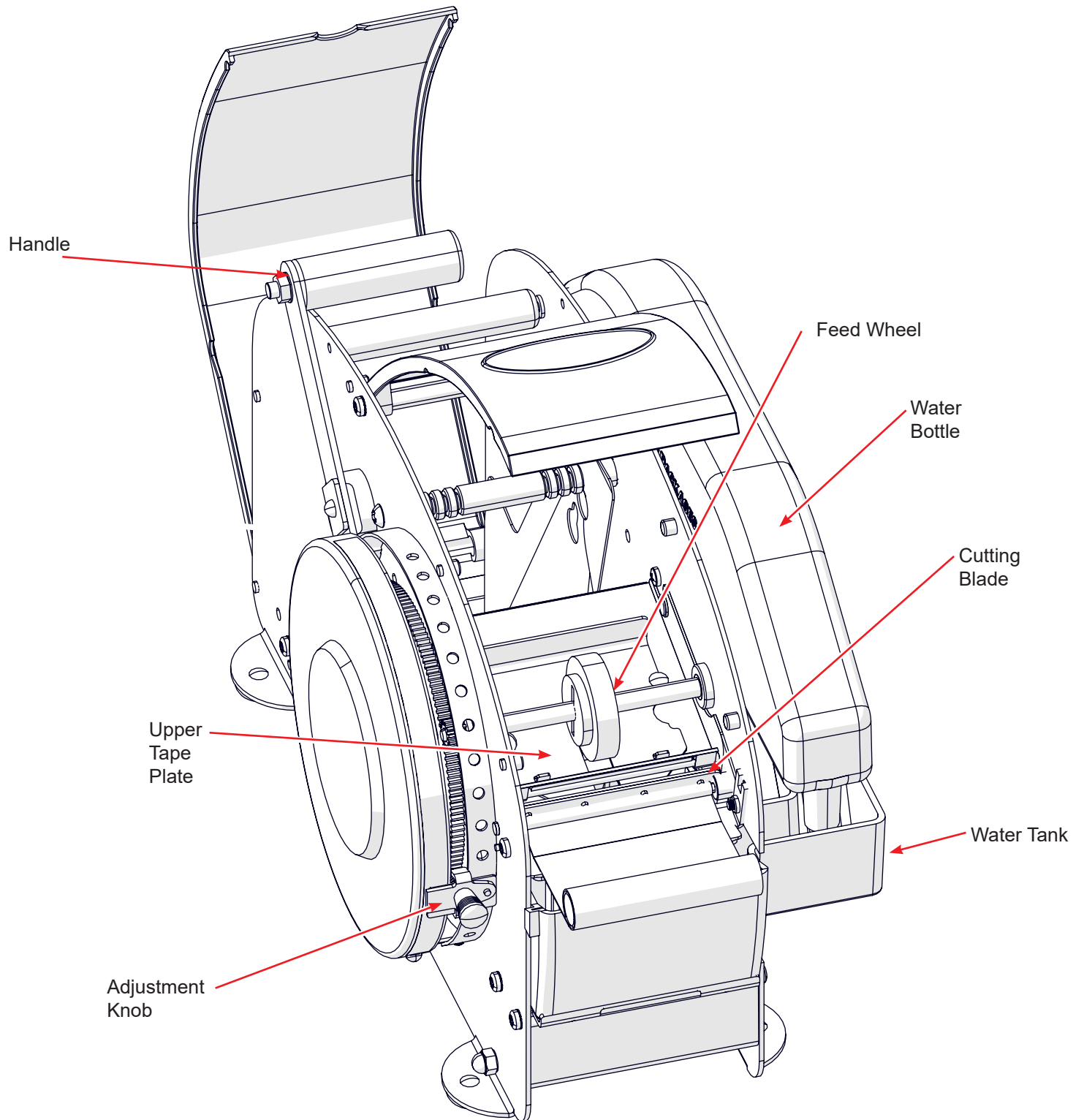

Figure 7: 555e Components

SPECIFICATIONS

Operating Conditions

Use in a dry, relatively clean environment at 40 to 105° F (5° to 40° C). Humidity not to exceed 90% at a temperature of 68° F (20° C). The 333 Plus will be capable of operating correctly at altitudes up to 10,000 ft. (3,000 m) above sea level.

Tape Requirements

Use only IPG Brand Water Activated Tape.

Maximum tape roll diameter of 7.75" (196mm) with a maximum tape roll length of 600ft (182.8m).

Technical Specifications

Dispensing Lengths: Up to 30 inches (76cm) in one stroke. Repeat pulls without returning the handle to its home position allows for longer tape dispenses.

Water Bottle Capacity: 46oz (1.3 liter)

Power Requirements Standard Dispenser: None

Power Requirements with optional heater: 110V 60Hz, 4A

Model Variations

333M

The Better Pack 333M has 15 preset tape lengths, in centimeters on a dial, ranging from 10cm -75cm. The BP333M uses **gummed side out tape** and is primarily used in Germany.

333CM

The Better Pack 333CM has 15 preset tape lengths measured in centimeters, ranging from 10cm -75cm on a clearly marked dial.

333J

Better Pack 333J has 15 preset tape lengths, measured in centimeters on a clearly marked dial, ranging from 10cm -75cm. The BP333J is used in Japan. This tape dispenser has special upper plates, lower plates and weights to accommodate 2" wide light tape grade. The 333J can also be equipped with an optional heater.

SET-UP PROCEDURE

Unpacking

After opening all the top flaps on the carton, you will find instructions for properly removing the dispenser and its included materials. It is recommended to keep all packing materials in case you need to ship the dispenser later or wish to pack and store it.

Verifying the Contents

Once the dispenser has been removed from the carton verify it has been shipped with all of the following items.

- Wetting Brush Qty 2 Part Number: [PW107AK](#)
- Water Tank Qty 1 Part Number: [FM6AX](#)
- Water Bottle Qty 1 Part Number: [FF6100](#)
- Upper Tape Plate Qty 1 Part Number: [FM12EL](#)
- User Manual Qty 1

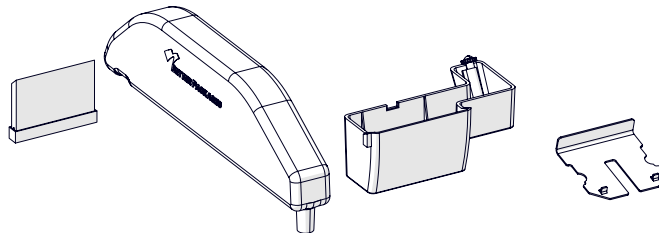

Figure 8: Included Components

Adjusting the Roll Guides

The roll guides are mounted onto a tie rod and seated into indexing grooves. The bottom of the guides fit into slots in the bottom of the tape basket. To adjust the position lift up on the guide (1) and move it to the desired indexing position (2).

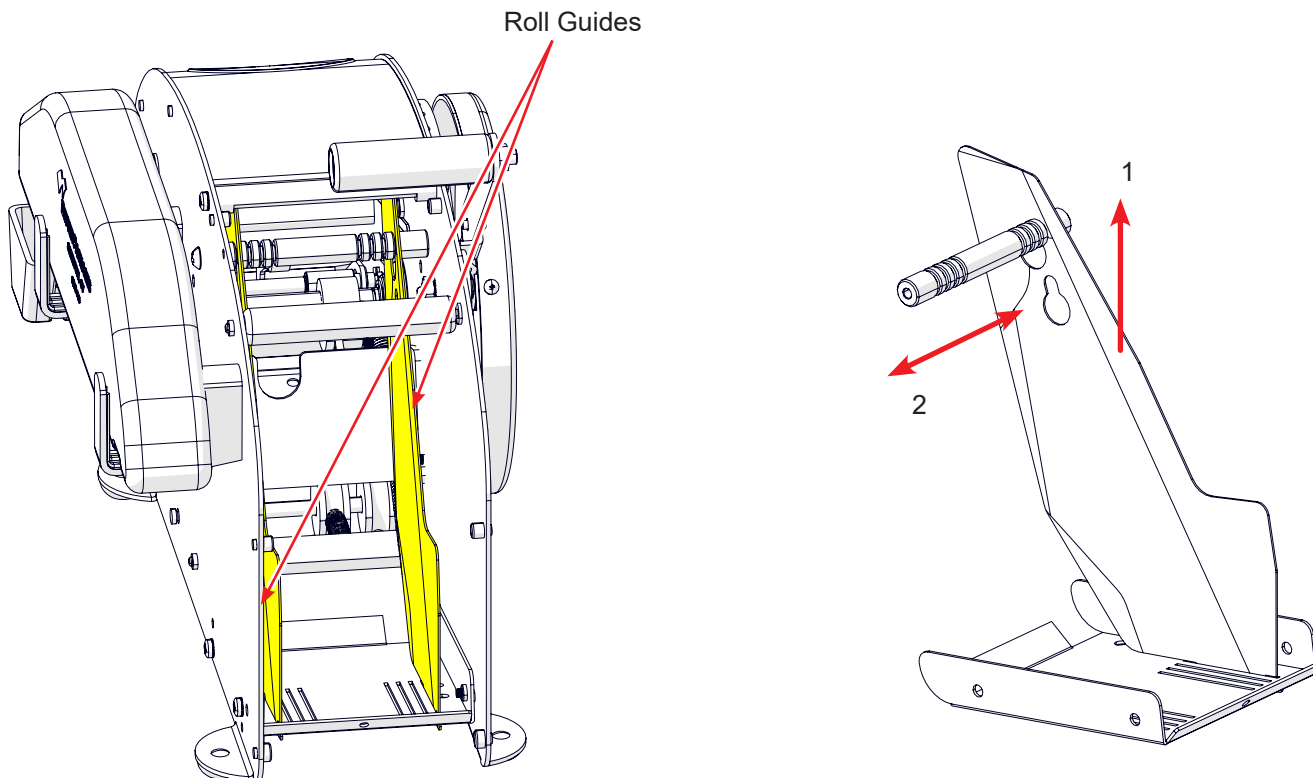

Figure 9: Roll Guides

SET-UP PROCEDURE

Loading the Tape Gum Side In

1. Open the lids.
2. Using scissors cut the end of the tape so it is a square clean cut.
3. Place the roll in the tape basket so that:
 - The roll is vertical.
 - The cut end comes from under the roll and over the back.
4. Feed the tape over the Black Roller and then over the Tie Rod.
5. Slip the tape under the upper tape plate and under the feed wheel. The tape should rest up to the blade.
6. Close the lids.

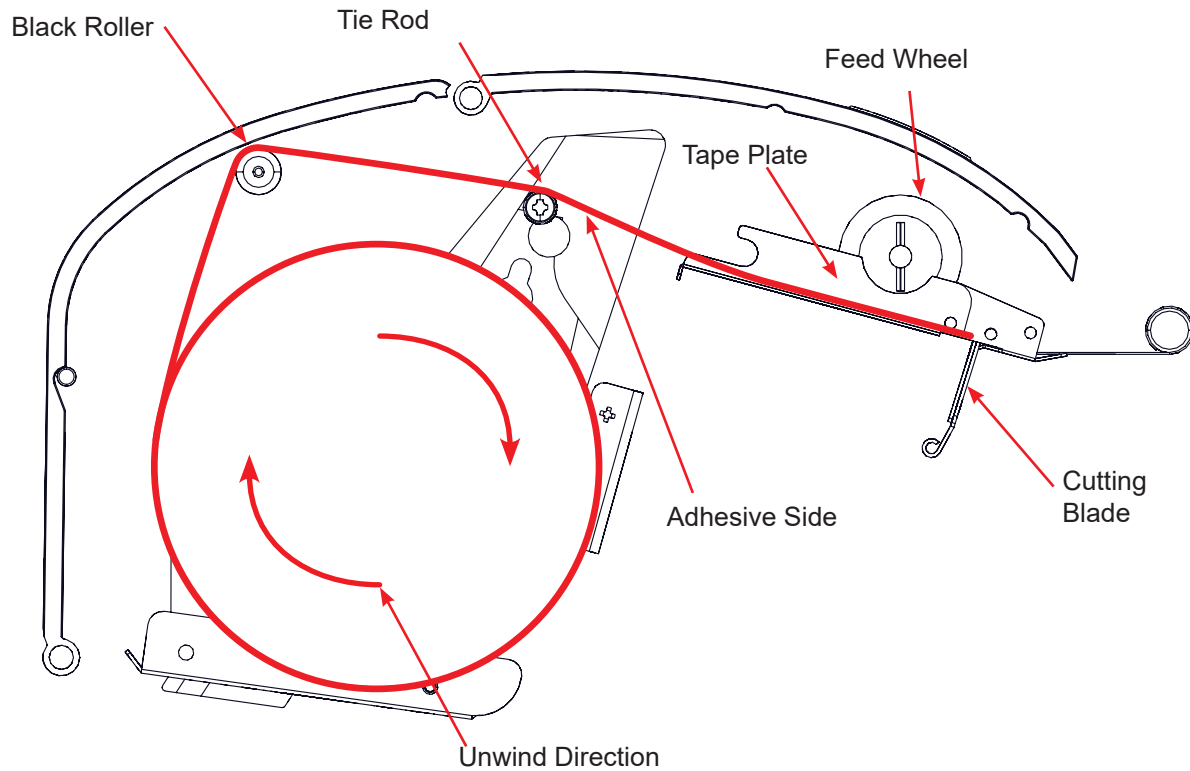

Figure 10: Gum Side In Tape Path

SET-UP PROCEDURE

Checking the Upper Tape Plate

Verify the upper tape plate is completely installed and in the proper position. If the tape plate is not in proper position remove it by grasping the bent upper portion and sliding it out toward the rear of the Dispenser. Verify the tape path is clean and dry before sliding the upper tape plate back into position. It should rest up to the guide bar and be seated around the feed wheel.

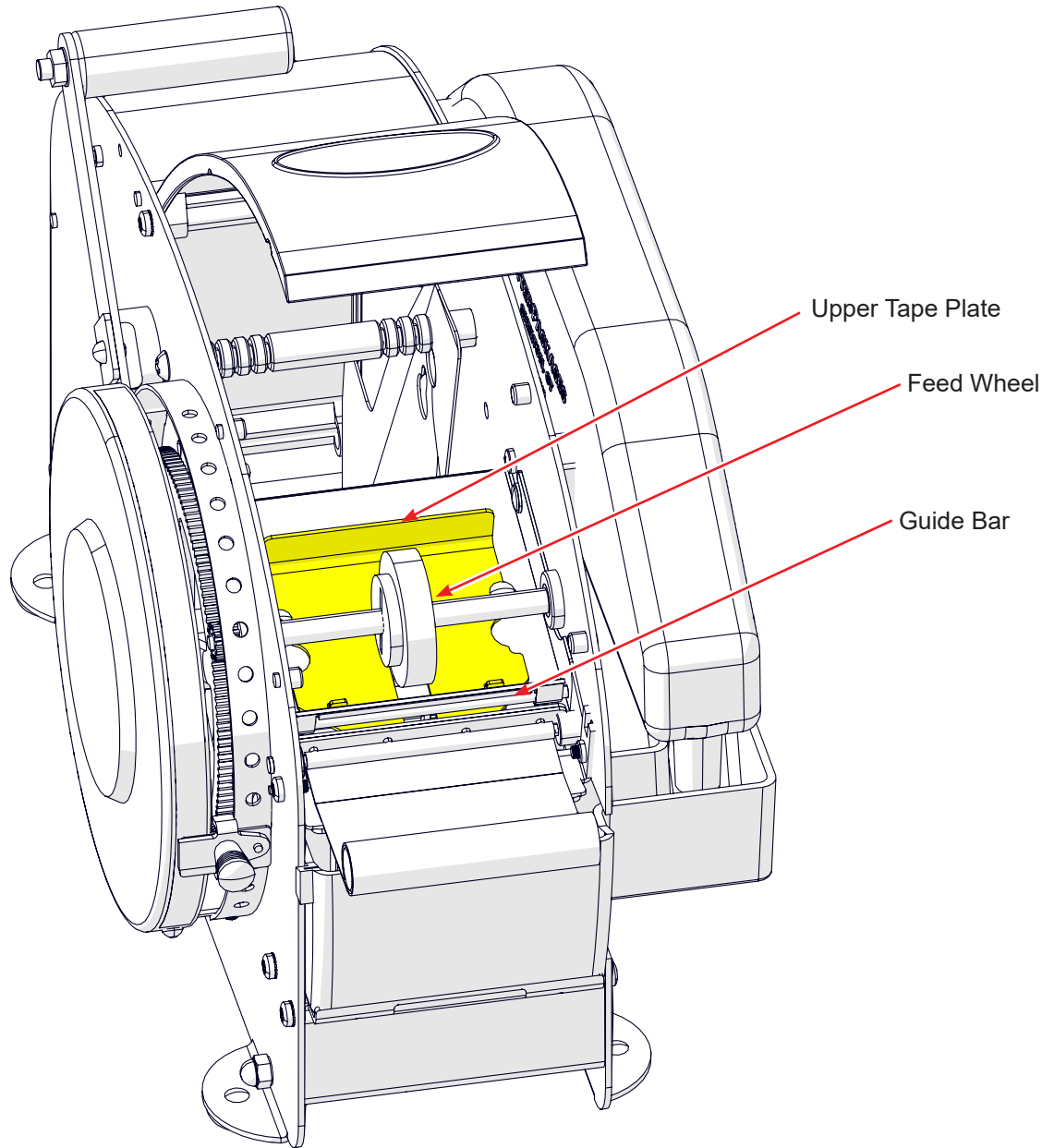

Figure 11: Upper Tape Plate

The Upper Tape Plate is vital for the correct functionality of the Dispenser. If the plate is not in position or is missing the tape will jam.

SET-UP PROCEDURE

Installing the Brushes and Water Tank

The 333 Plus comes with two brushes. Installing both are necessary for the proper operation of the dispenser.

To install the brushes:

1. Orient the brush in the proper direction with the shortest bristles closest to the rear of tank.
2. Place the brush in the opening allowing it rest against the molded ribs of tank.
3. Place the second brush in the same orientation against the first.
4. The brush is properly installed when the bristles are flat across the top of the tank.

Water level can be adjusted with a screw on the right side of the water tank. Rotating it counterclockwise will increase the level of water in the tank.

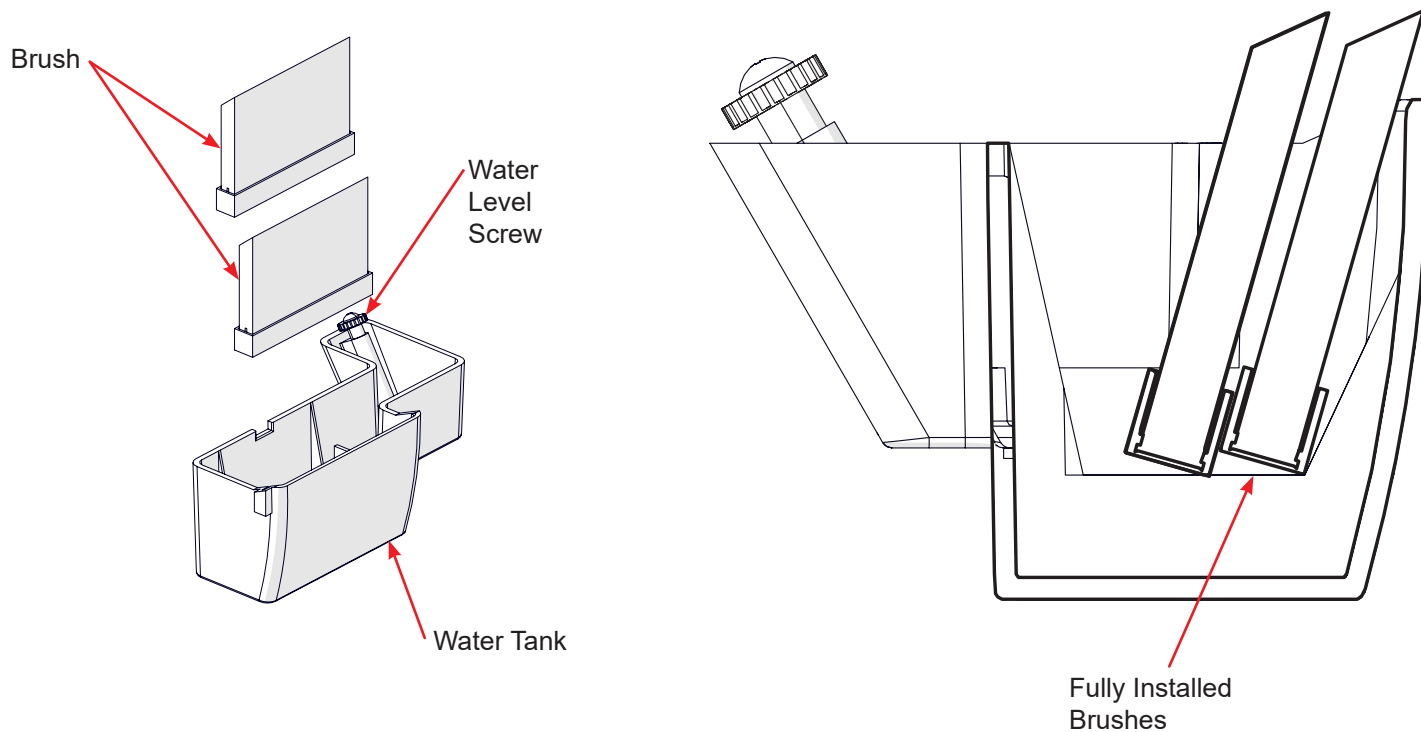

Figure 12: Brush Install

SET-UP PROCEDURE

Water Tank Install

1. If in place remove the water bottle.
2. Grip the tank from end opposite of the brushes.
3. Angle the assembled tank back slightly to allow the brushes to slip under the weighted plate.
 - If necessary the plate can be lifted to allow for easier install.
4. Lift up slightly and tilt the bottom of the tank into the machine. The base of the tank has a small lip around it locking the tank on the tank shelf.
5. Give the tank a slight nudge back and forth to verify it is fully seated on the shelf.

Water level can be adjusted with a screw on the right side of the water tank. Rotating it counterclockwise will increase the level of water in the tank.

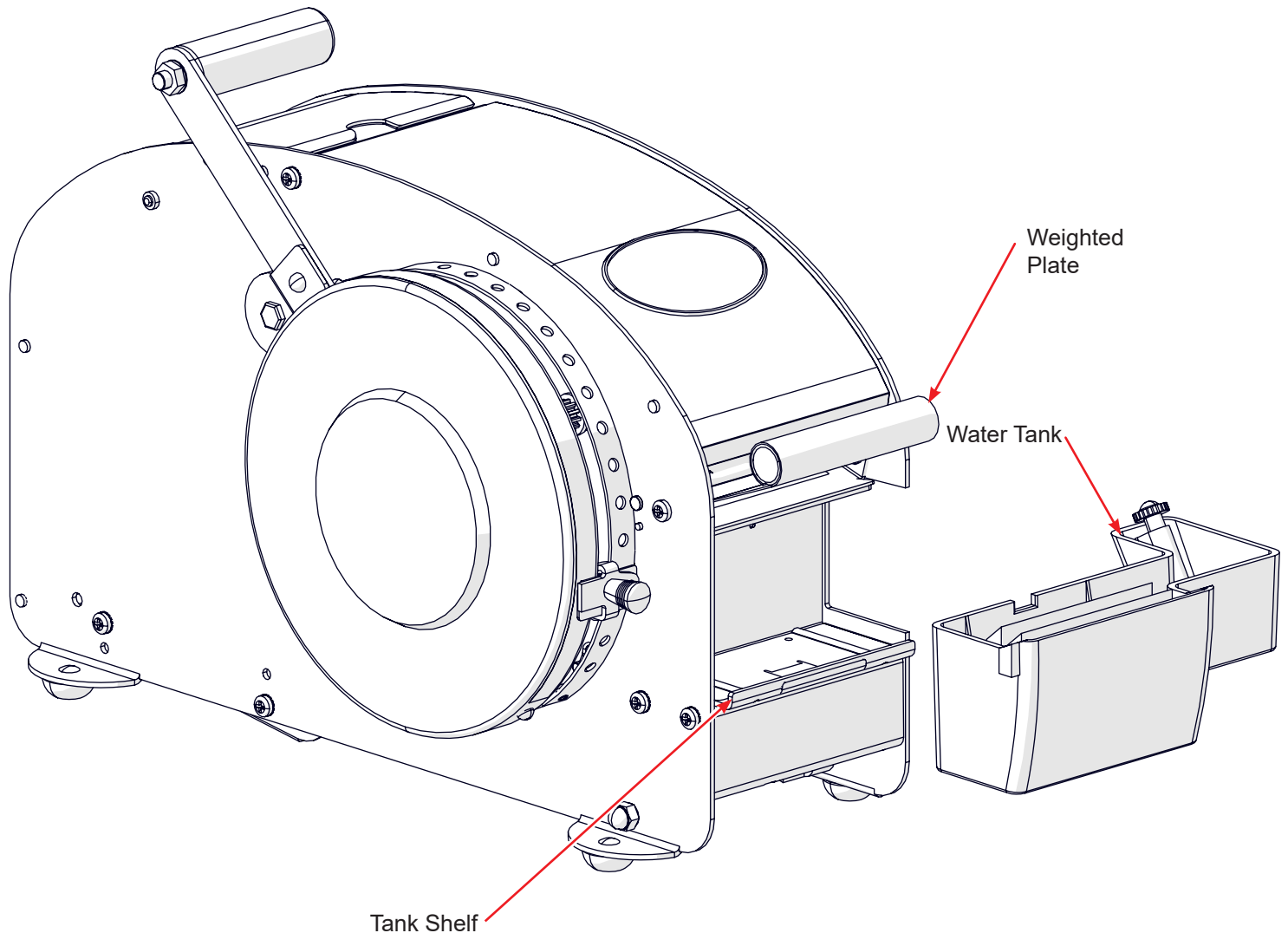

Figure 13: Water Tank Install

If the optional heater is installed only grip it from the attached handle if it needs to be lifted out of the way.



CAUTION: UNDER NORMAL OPERATIONAL CONDITIONS THE BOTTOM OF THE HEATER WILL BE HOT. HANDLE THE HEATER ONLY USING THE TABS ON EITHER SIDE OF THE HEATER OR ALLOW TIME FOR THEM TO FULLY COOL BEFORE HANDLING.

SET-UP PROCEDURE

Water Bottle Install

The 333 Plus dispensers all use the same 46oz (1.3 liter) water bottle. Fill it with room temperature or warm water for best results. There is no need for any special water such as distilled water. In the event your facility has hard water or water with a higher than normal mineral count you may want to consider using filtered water. Use caution when transporting as the bottle has no cap.

After filling the water bottle place your thumb on the spout to seal the bottle. Position the bottle over shelf, with the spout over the water tank. While lowering the bottle onto the brackets remove your thumb from the spout. Once fully seated water will flow into the tank until it reaches the spout forming a seal.

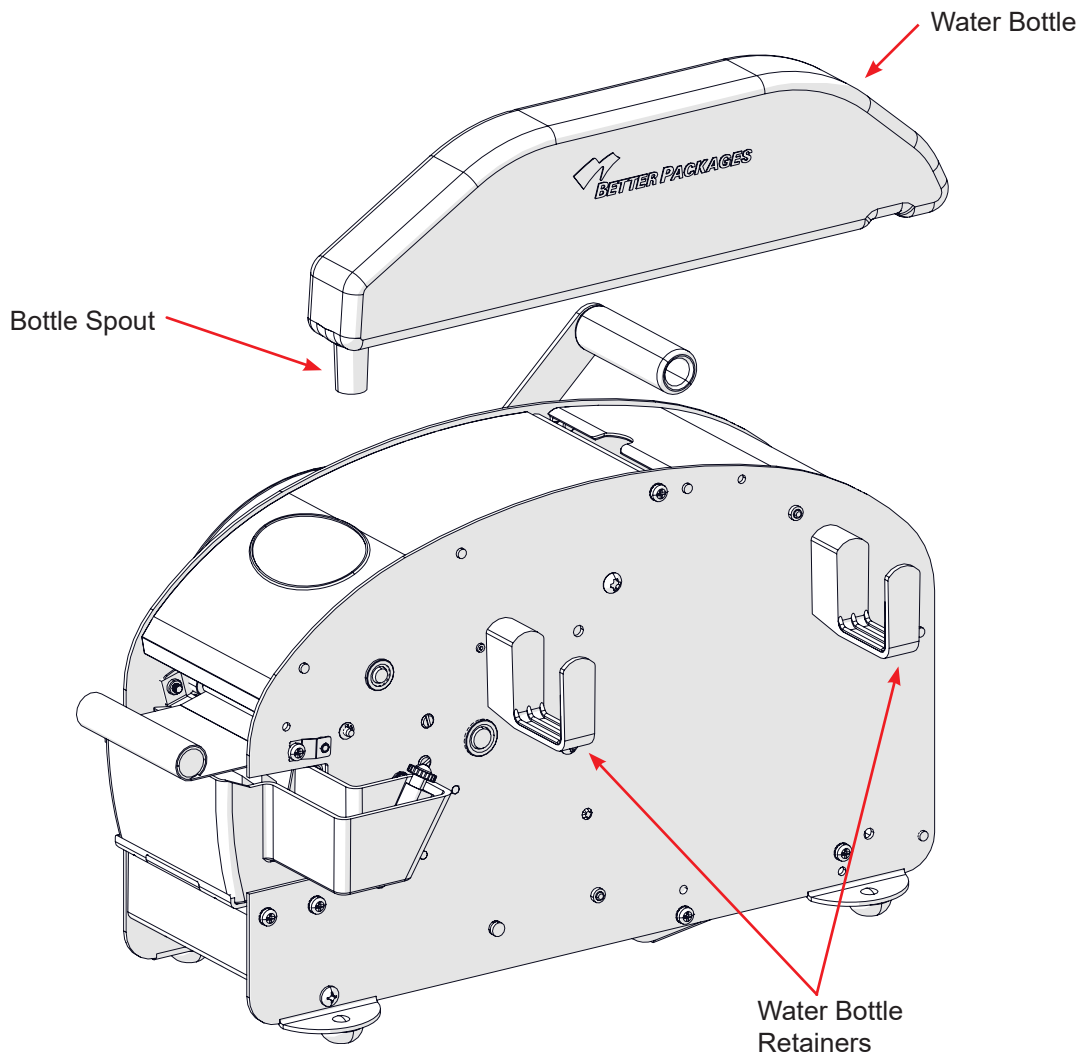

Figure 14: Water Bottle Install

OPERATION

General Operating Procedures

The 333 Plus is a manually operated dispenser that does not need any power for operation.

Verify tape is loaded correctly. If no tape is loaded see the section titled [Loading the Tape](#) for more details.

Selecting the Length of Tape

The 333 Plus has an adjustable Feed Stop with locking points every 2 inches (5mm) from 4 inches (10mm) to 30 inches (76mm) in length. To move the feed stop pull the knob away from the dispenser and slide it along the drum until you reach the desired length. Release the knob so the feed stop can lock into one of the indexing points.

The 333M and 333CM has locking points every 5cm from 10cm to 75cm.

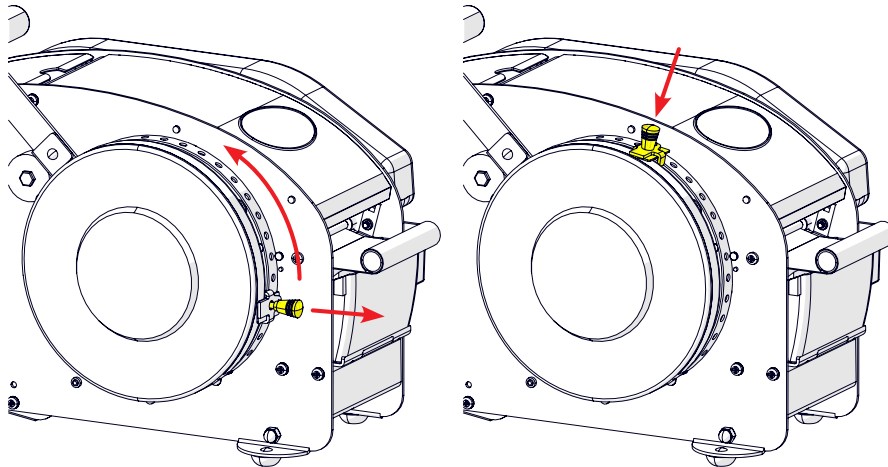

Figure 15: Selecting the Tape Length

Dispensing Tape

Grip the handle and pull it toward the front of the dispenser. This will drive the tape out of the dispenser. Pull until the arm reaches the feed stop or desired length. Releasing the handle to its home position will engage the blade and cut the tape. If longer strips are needed move the handle back to the 4 inch mark and pull again. This can be done as many times as needed for the length of the tape.

The operator may then grip the tape from the edges and place it on the carton.



WARNING: DO NOT PULL THE HANDLE WHILE THE COVERS ARE OPEN. THE BLADE OPERATES ON A SPRING MECHANISM AND CAN RESULT IN INJURY.

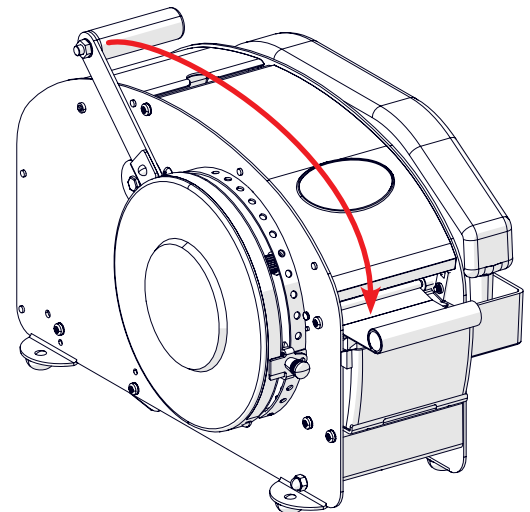

Figure 16: Dispensing Tape

APPLYING TAPE TO A CARTON

Choosing the Correct Tape Type

TYPE	CHARACTERISTIC
Paper Tape or Kraft Paper Tape	Made from paper only, with no additional reinforcing material
Reinforced Tape or Reinforced Paper Tape	Made from paper and contains additional strands of reinforcing material, typically fiberglass

IPG offers a variety of different grades of [Paper Tape or Kraft Paper Tape](#). In most circumstances this non-reinforced tape is good for smaller and lighter cartons.

IPG offers a variety of different grades of [Reinforced Tape or Reinforced Paper Tape](#). In most circumstances this reinforced tape is good for larger boxes and those with increased weight.

[Contact](#) your Authorized IPG Representative for the best tape for your applications.

Choosing the Correct Tape Length

In most situations it is recommended to dispense a length of tape that is equal to the length of seam on the carton with an additional 4-6 inches (101-152mm) to allow for tape legs on either end of the carton.

In the event the carton is extremely long an additional 6-8 inches (101-203mm) is recommended for tape legs.

In the event the carton is short an additional 3-4 inches (76-101mm) is may be used.

Proper Tape Moistening

Dispense a piece of tape and examine the adhesive surface. The tape should:

- Be evenly wet
- Have no dry spots
- Have no spots where water is running off the surface.

Rub the wet adhesive with your finger.

- The adhesive should have an “oily” feel and consistency.
- You should be able to move the adhesive underneath your finger.

When you rub two wet adhesive surfaces of the tape together against each other, you should see “strings” of adhesive stretching between the two surfaces as you pull them apart, looking much like taffy as it is pulled.

If the tape is too wet or watery, it:

- Will not set fast enough
- May slip slightly over the surface of the carton, causing a “loose” seal If the tape is not wet enough, it:
- May be tacky or sticky like pressure sensitive tape, but not “oily” like properly moistened tape.
- Is too dry to properly activate the adhesive which will prevent a permanent bond from forming (because the adhesive cannot penetrate the corrugate fibers).
- May too easily pull off the carton during handling and transportation.

APPLYING TAPE TO A CARTON

Sealing the Carton

The best way to apply the tape to the carton is:

1. Place the wet tape on the end of one of the flaps to be sealed so that:
 - Half of the tape's width is on one flap
 - The other half is overhanging
2. Fold the flap without the tape down to its closed position.
3. Fold the other carton flap (the one with the overhanging tape) down into its proper closed position so that the overhanging portion of the tape is now in contact with the other flap on the opposite side of the carton.
4. Starting from the middle of the carton, apply a light downward pressure and wipe your hands over the tape on top of the carton flaps. Move from the center to the sides and then down over the overlapping ends in the sides of the carton. Sometimes wiping the tape down a second time before releasing the carton is helpful

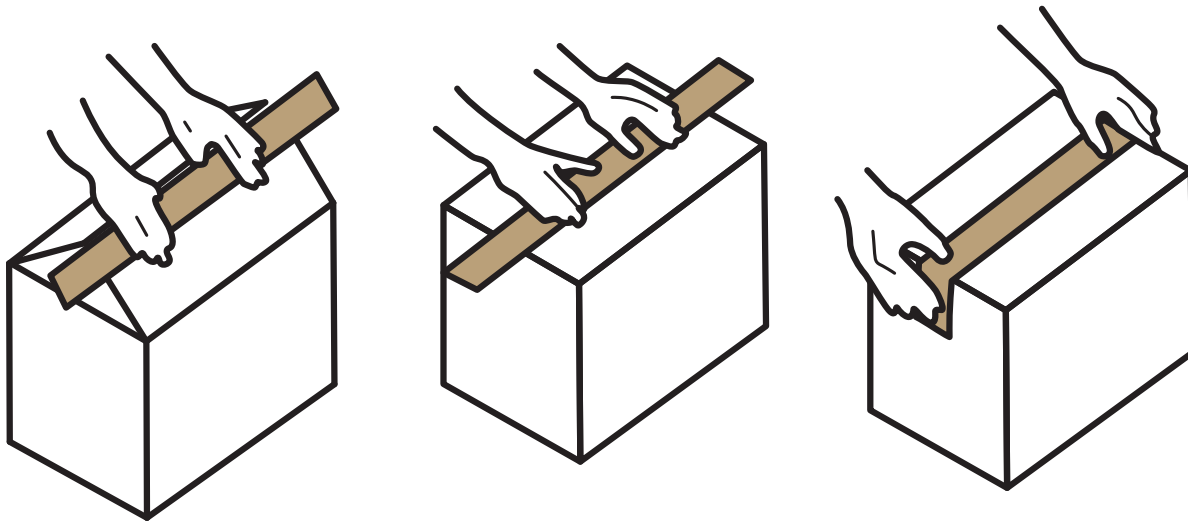

Figure 17: Applying Tape

Common Tape Patterns

The following are commonly used tape patterns. **“H” pattern** or sometimes referred to as the **“I” pattern** is when the center seam is sealed as normal and two more strips of tape are applied to seal the sides of the minor flaps. This allows for a secure and aesthetically pleasing carton. The **“Belly Band”** is when a strip of tape is placed in the opposite direction of the center seam. This helps secure heavier loads and is applied to the top and bottom of the box. The **“X” pattern** is more rarely used but is considered the most secure and is a cross between the “H” pattern and the “Belly Band.” It is used for extremely heavy items.

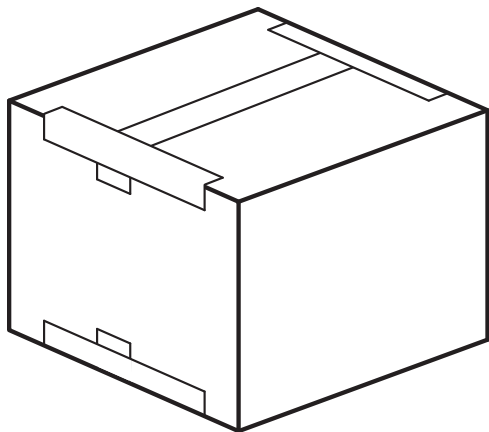

Figure 18: “H” Pattern

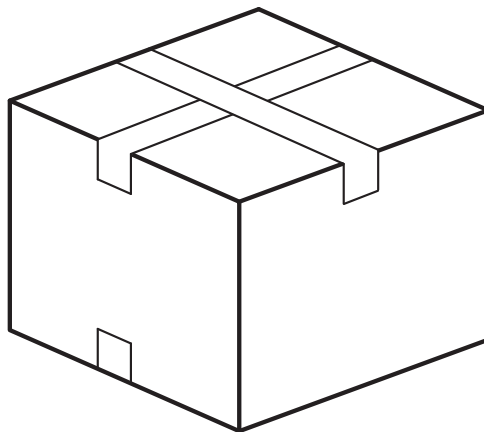

Figure 19: Belly Band

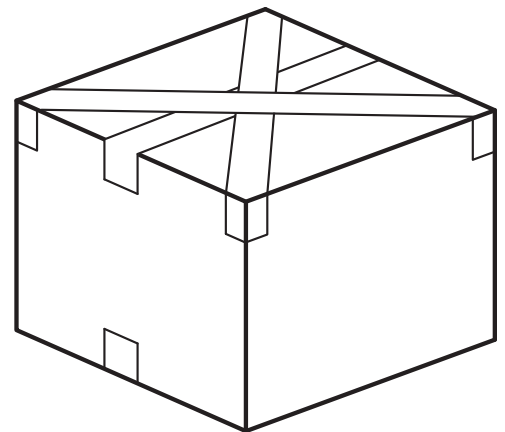

Figure 20: “X” Pattern

PREVENTATIVE MAINTENANCE

Suggested Preventative Maintenance Schedule



WARNING: THE CUT-OFF BLADE IS EXTREMELY SHARP USE CUT RESISTANT GLOVES WHEN SERVICING OR REPLACING THE BLADE. IF THE OPTIONAL HEATER IS INSTALLED IT WILL BE HOT. ALLOW TIME TO COOL PRIOR TO SERVICING.

Weekly

- Wash brushes with mild soap and water. Rinse well to remove all soap residue.
- Clean any accumulated dust with a dry brush or blower.
- Wash water tank with mild soap and water. Rinse well to remove all soap residue.

Monthly

- Clean accumulated glue from blades using a scraper. Do not scrape the cutting edge of the blade this can cause damage and may result in needing to change the blade.
- Apply a light coating of a light machine oil to the back of the blade.
- Add only a few drop of a light machine oil to felt pads.

Annually

- Thoroughly clean all accumulated pieces of tape, dust, and any other foreign material from inside the Dispenser with a dry brush or blower.
- Clean the bottom of the weighted plate or optional heater and pressure plates of accumulated tape adhesive.
- Clean all covers with a damp rag.

Washing the Tank, Brush, and Bottle

Water Brush: Glue from the tape may accumulate and reduce the effectiveness of the moistening system. Wash brushes weekly with mild soap. Be sure to agitate the bristles while in the soap and water solution. A brush is considered clean after this agitation and all adhesive build up has been removed.

It is recommended to soak brushes in a solution of mild soap and water overnight. This will reduce any adhesive build up and extend the life of the brushes.

If you operate multiple machines all brushes may soak in the same container.

Rinse the brushes in running warm water before reinstalling them into a clean water tank.

Water Tank: Glue from the tape may accumulate in the water tank. This build up can accumulate in the water brushes and result in a reduction of water transmission to the tape and a weaker bond to the carton.

It is recommended to wash the water tank once a week in a warm soap and water solution. Use a low-scratch abrasive brush to clean the bottom of the water tank as well as the tight areas. Rinse the water tank in running warm water before reinstalling.

Water Bottle: Hard water build up may appear in the water bottles over time. If you have hard water or other mineral rich water it is recommended to use a filtered water to extend the life of the water brush as well as the seal in the water bottle cap.

It is recommended to wash out the water bottle once a week with a warm soap and water solution. Fill the bottle $\frac{1}{4}$ to $\frac{1}{2}$ with the soap and water solution. Seal the bottle, then shake the bottle vigorously. Allow the bottle to drain before rinsing with warm water. Allow the water bottle to fully dry before reusing.

In extreme circumstances the water bottle may be cleaned with a white vinegar and water solution but it would be recommended to replace the water bottle.

The adhesive is non-toxic and water soluble. If adhesive builds up on an operator's hands, washing with soap and water will remove any debris. Standard packing gloves or other required PPE should be used in accordance with plant policies where the dispenser is being operated in.

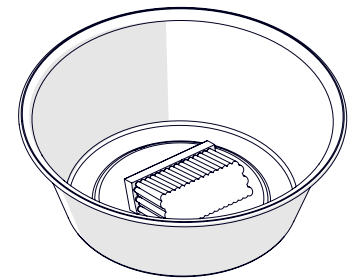

Figure 21: Brush Cleaning

TROUBLESHOOTING

PROBLEM	POSSIBLE CAUSES	SOLUTIONS
Tape is too short	Feed wheel is out of adjustment	Conduct a feed wheel check and adjustment.
Tape is too long	Damaged gear	Remove left side drum cover and verify the integrity of the gears.
Dispenser not outputting tape	Tape is not under the feed wheel	Verify the tape has been threaded correctly and is under the feed wheel.
	Upper tape plate is missing	Open the cover and verify the tape plate is installed.
	Stripped gear	Remove left side drum cover and verify the integrity of the gears.
	Pawls are not engaging	Remove left side drum cover and verify the integrity of the pawls and pawl springs.
Poor tape wetting	Low water level	Adjust the height of the Water Bottle using the screw knob on the Water Tank.
	Dirty application brushes	Soak the brushes in warm water and clean with mild soap.
	Tape is not making contact with the brushes	Verify the weighted plate or optional heater is properly mounted and not damaged.
	Water Bottle empty	Refill the Water Bottle
Tape Jams	Upper tape plate is missing	Open the cover and verify the tape plate is installed.
	Damaged weight plate or optional heater	Contact IPG Machinery Support

For Set-up, Operation, and Maintenance Videos please visit www.betterpackages.com/tape-dispenser-videos/

If you are experiencing trouble with your Dispenser or it is functioning in a way that is not consistent with this manual please contact IPG Machinery Support at +1 813-345-3070 between the hours of 8am and 7pm Eastern Standard Time or via email at machsupp@itape.com.

Proper preventative maintenance will improve the longevity of the 333 Plus Dispenser extending its life to decades.

TROUBLESHOOTING

Spring Identification

The 333 Plus contains two main springs, two blade springs, and one spring for the rocker stop bar.

The main spring FM-48-AX (yellow below) is attached to the front of the dispenser and the cam attached to the handle shaft. The main spring FM-33-AX (red below) is connected to the tape basket and a shaft on the cutting yoke, this helps the return of the blade to cut the tape when the handle is returned to its home position.

The two blade springs FM-21-X (not pictured) help keep the stationary blade firmly pressed against the shear blade as its position moves in the dispensing operation. These are affixed to either side of the stationary blade and spring mounts on either side frame.

The rocker stop spring FM-23-HD (not pictured) keeps the rocker stop bar in an optimal position while the yoke moves during the dispensing process. This is affixed to a cotter pin on the rocker stop bar and a spring mount on the right side frame.

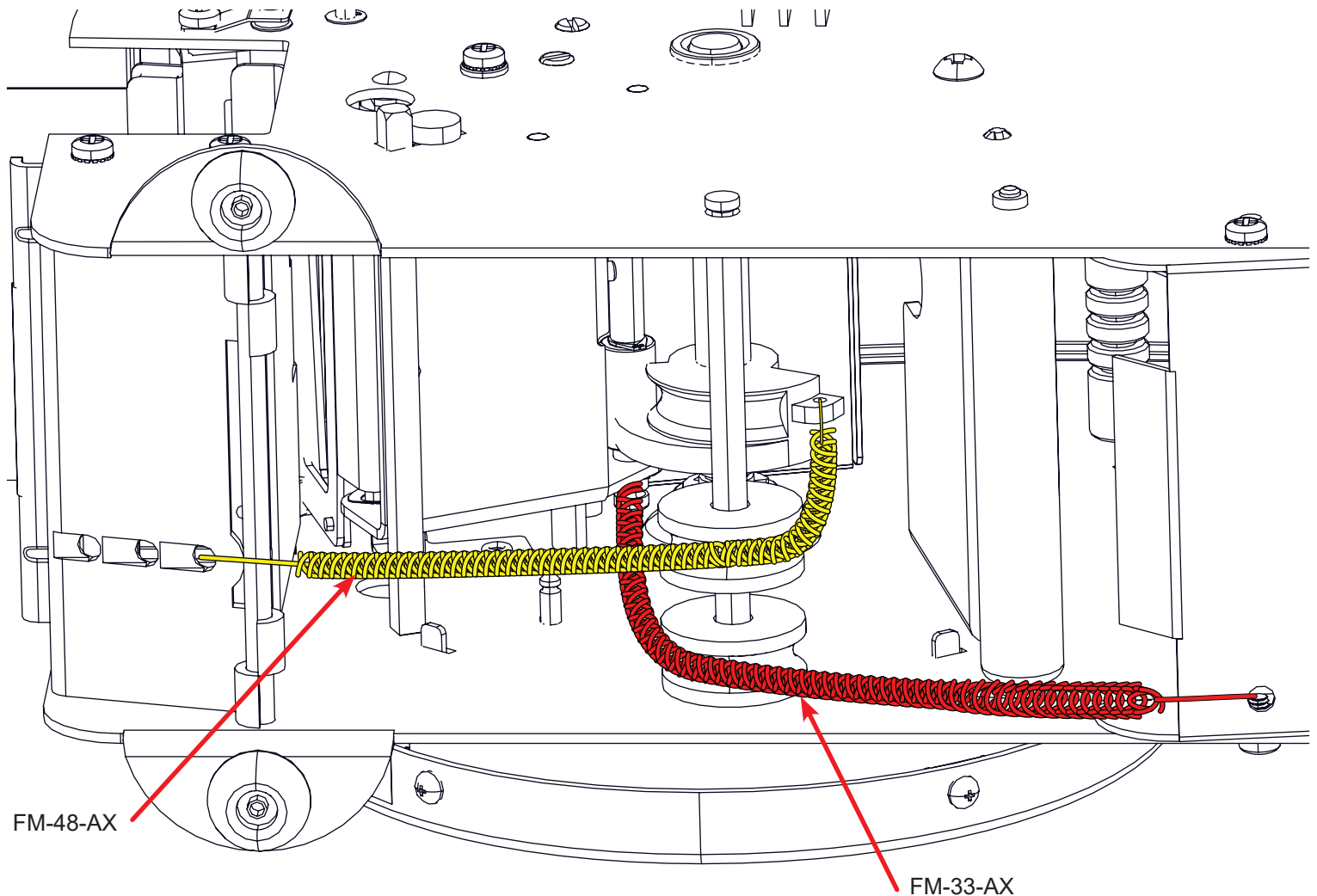

Figure 22: Springs

APPENDIX

Parts Listing

Appendix

Single Components	30
Assembly Components	30
Kit Components	30
Water Components	31
Left Frame Assembly	32
Right Frame Assembly	33
Top Covers and Tape Basket	34
Cutting Assembly	35
Tape Cutting Assemblies	36
Handle	37
Part Kits	38

Parts in the 333 Plus can be categorized into one of two categories:

1. Single Components, shown by a white balloon call out.
2. Assembly Components, shown by a black balloon call out, these are sold as a unit.
3. Kits that are comprised of multiple parts for ordering convenience, shown by having a box around a group of parts.

*Components with multiple call outs will have the associated 333 Plus model in the description. If you are unsure of the model of your 333 Plus please contact IPG Machinery Support +1 813-345-3070 or machsupp@itape.com.

To order parts please contact Better Packages Customer Service 1-203-926-3700 or 1-800-237-9151 (United States only), parts can also be found directly at www.betterpackages.com/parts

Single Components

Assembly Components

Kit Components

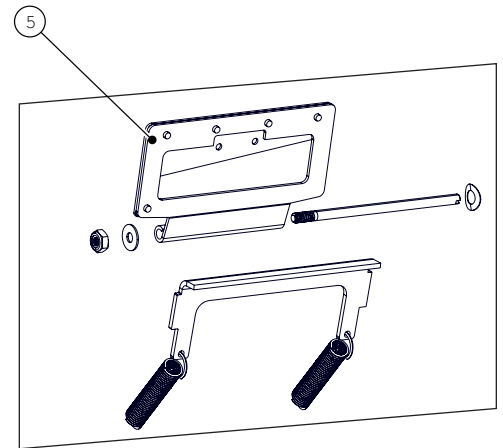
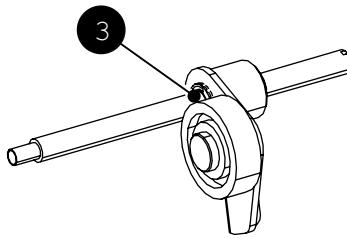
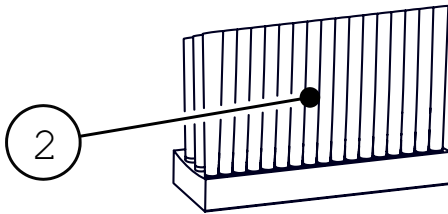

Recommended Spare Parts

The following is a list of parts that is recommended to keep on hand.

Description	Item Number	QTY
Brushes (2 count)	PW107AK	1
Upper Tape Plate	FM12EL	1
Driving Spring	FM48AX	1
Handle Return Spring	FM33AX	1
Feed Wheel	E55506500	1

APPENDIX

Water Components

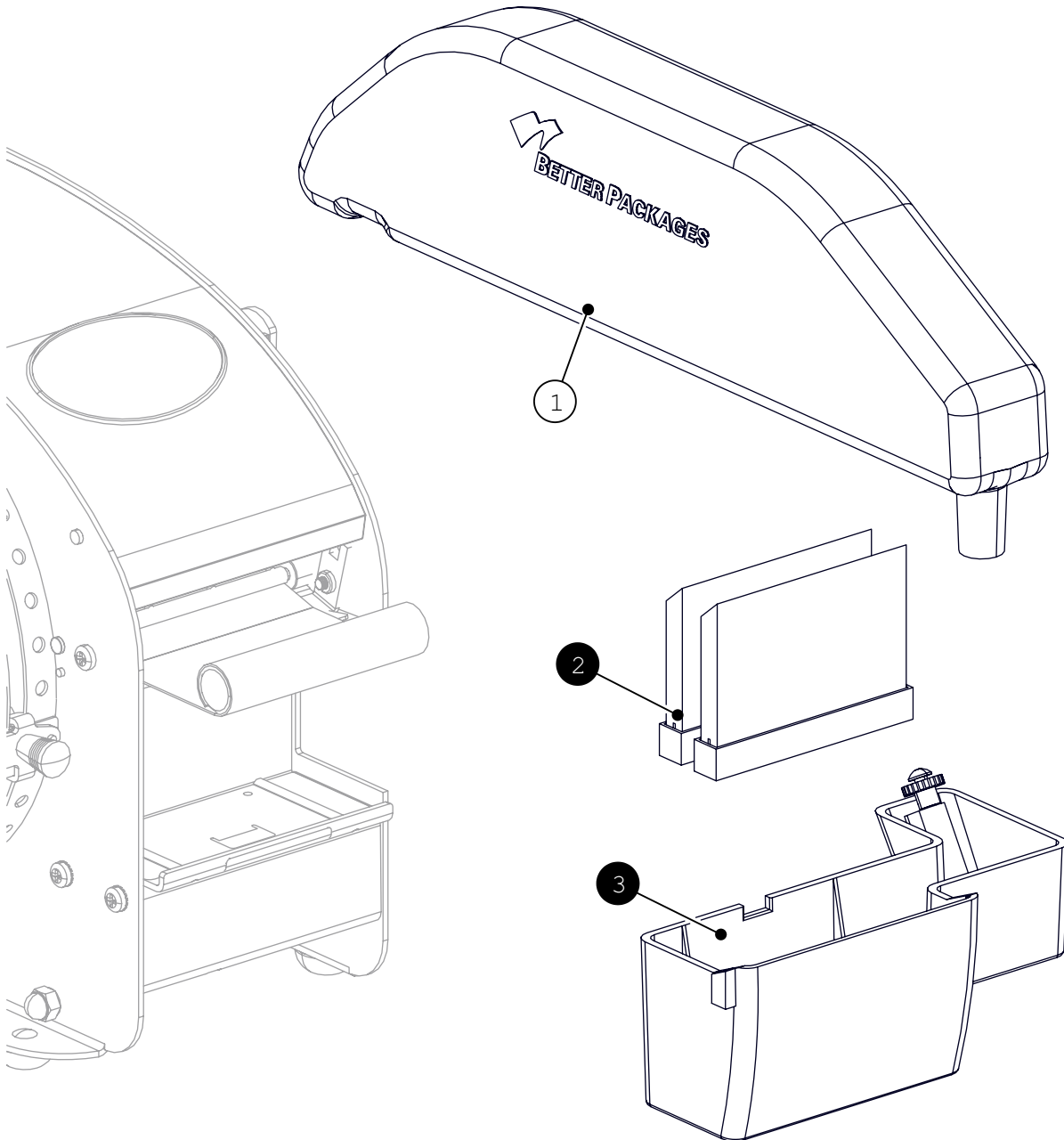

ITEM	PART NUMBER	DESCRIPTION	QTY
1	FF-610-0	WATER BOTTLE	1
2	PW-107A-K	BRUSK KIT	1
3	FM-6-AX	WATER TANK ASSY	1

APPENDIX

Left Frame Assembly

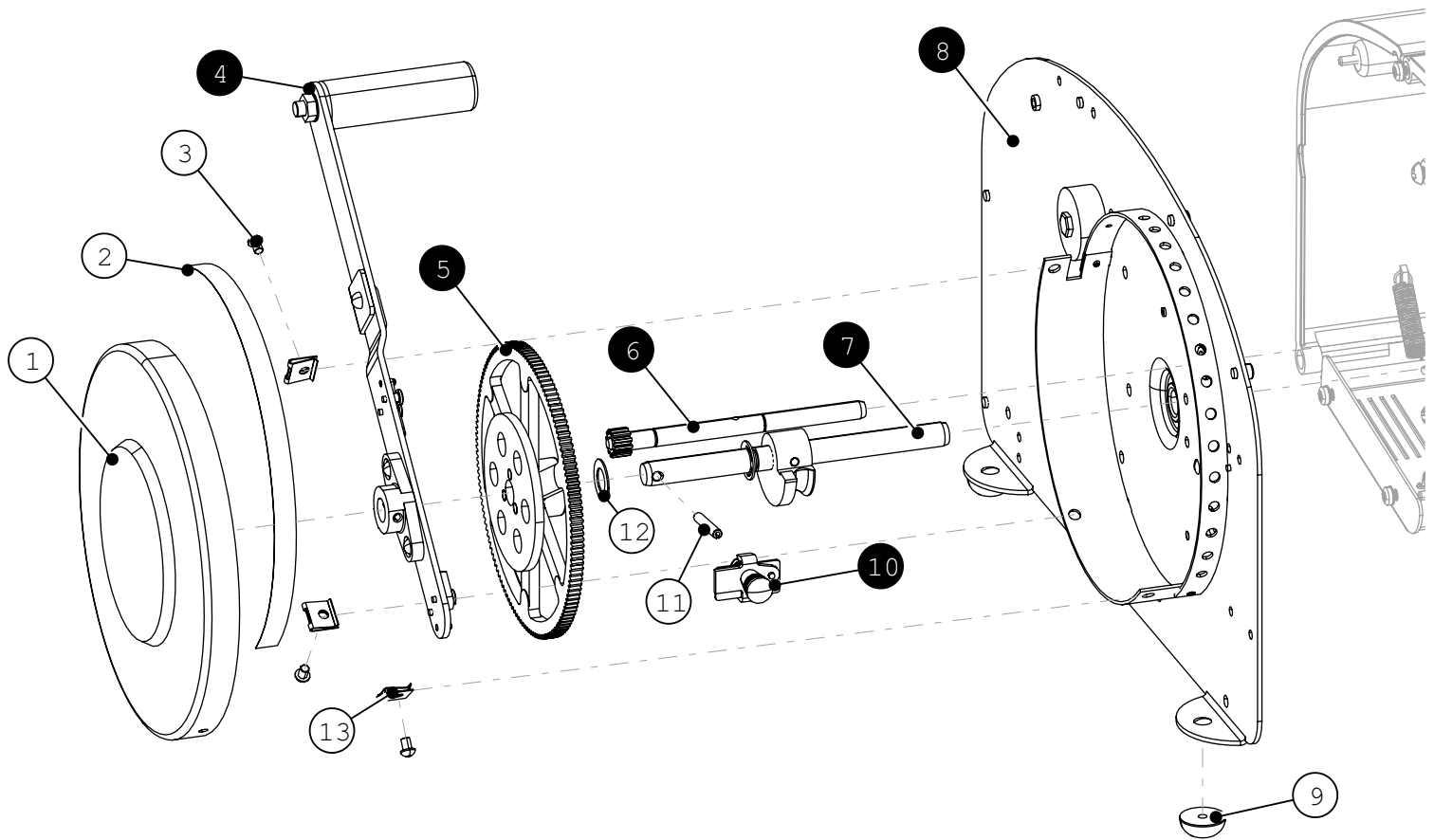

ITEM	PART NUMBER	DESCRIPTION	QTY
1	FM-80	DRUM	1
2	FM-79	SCALE NAMEPLATE	1
3	FM-99	#10-24 x 3/8" PHILLIPS	3
4	FM-41-FX	CRANK HANDLE ASSY	1
5	GE-79-X	DRIVE GEAR ASSY	1
6	FM-49-X	SHAFT PINION SUB-ASSY	1
7	FM-460X	SHAFT CAM ASSY	1

ITEM	PART NUMBER	DESCRIPTION	QTY
8	FM-1-FX	L FRAME COMPLETE SUB ASSY	1
9	A-47	RUBBER FOOT	1
10	FM-110-XX	FEED STOP ASSY	1
11	K-50CR	ROLL PIN 3/16 x 1 1/4"	1
12	K-35-A	WASHER 1/32	1
13	FM-100	NUT TINNERMAN	3

APPENDIX

Right Frame Assembly

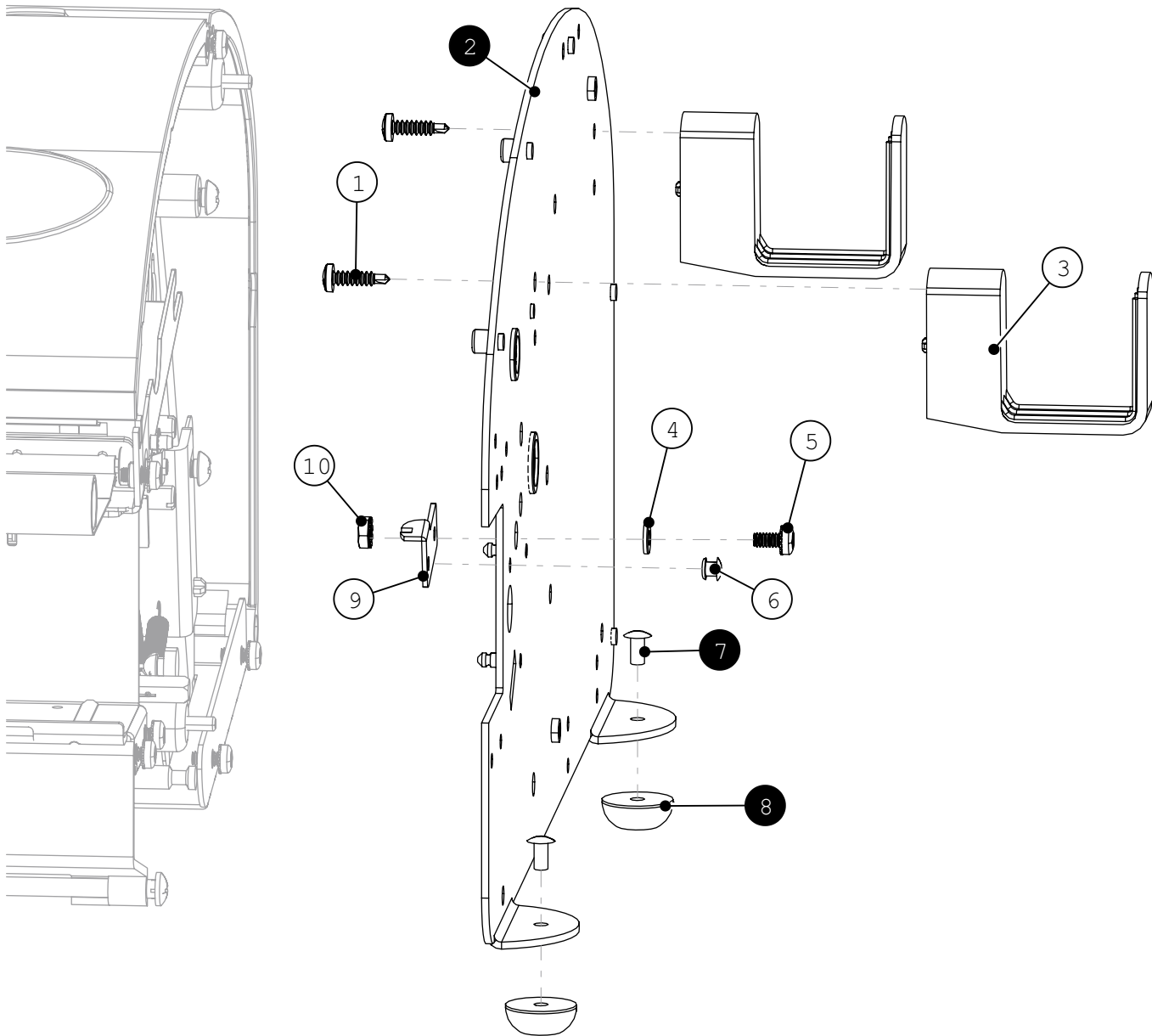

ITEM	PART NUMBER	DESCRIPTION	QTY
1	0237710	#10-16 x 3/4" PHILIPS	2
2	FM-2-FX	R FRAME COMPLETE SUB ASSY	1
3	FF-612-P	BOTTLE BRACKET	2
4	FM-14	WASHER	1
5	ST-1949	#10-24 x 3/8" PHILIPS	1
6	FM-90	RIVET 3/16 x 1/4"	1
7	PW-17-NK	RIVET 3/16 x 3/8" PACK OF 2	1
8	A-47-K	RUBBER FOOT PACK OF 4	1
9	FM-22-R	RIGHT SHEAR BRACKET	1
10	ST-2890	#10-24 KEPS NUT	1

APPENDIX

Top Covers and Tape Basket

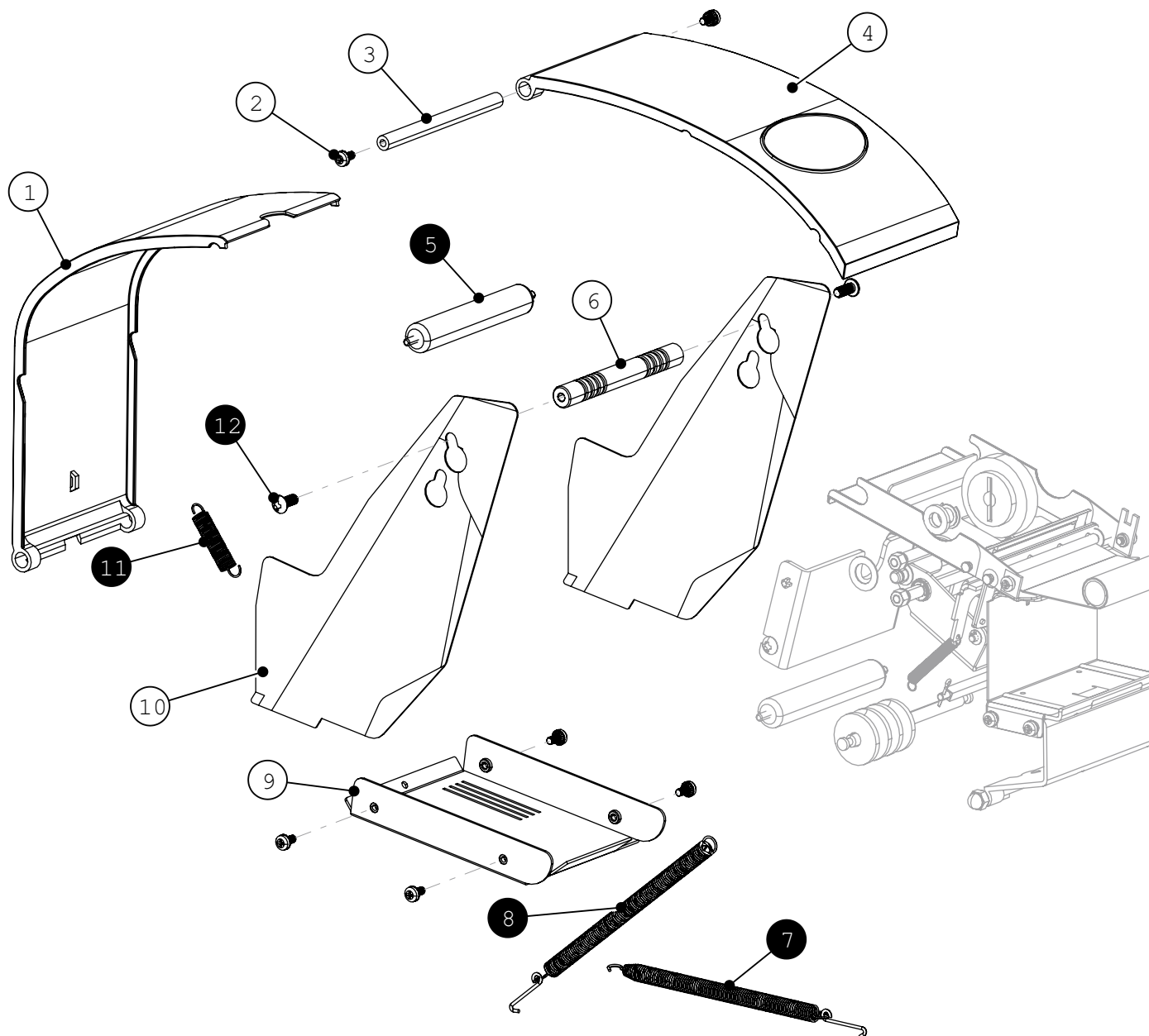

ITEM	PART NUMBER	DESCRIPTION	QTY
1	FM5	COVER	1
2	ST-1949	#10-24 x 3/8" PHILIPS	6
3	FM-117	TIE ROD	1
4	FM4	COVER	1
5	FM-59-X	TAPE ROLLER ASSY	1
6	FM-56	SLOTTED TIE ROD	1
7	FM-48-AX	SPRING HOOK ASSY TAPE DRIVE	1
8	FM-33-AX	SPRING HOOK SUB ASSY HANDLE RETURN	1
9	FM-57-X	TAPE BASKET	1
10	FM-310	ROLL GUIDE	2
11	FM-64	SPRING	1
12	TO-256	1/4-20 x 1/2" PHILIPS	2

APPENDIX

Cutting Assembly

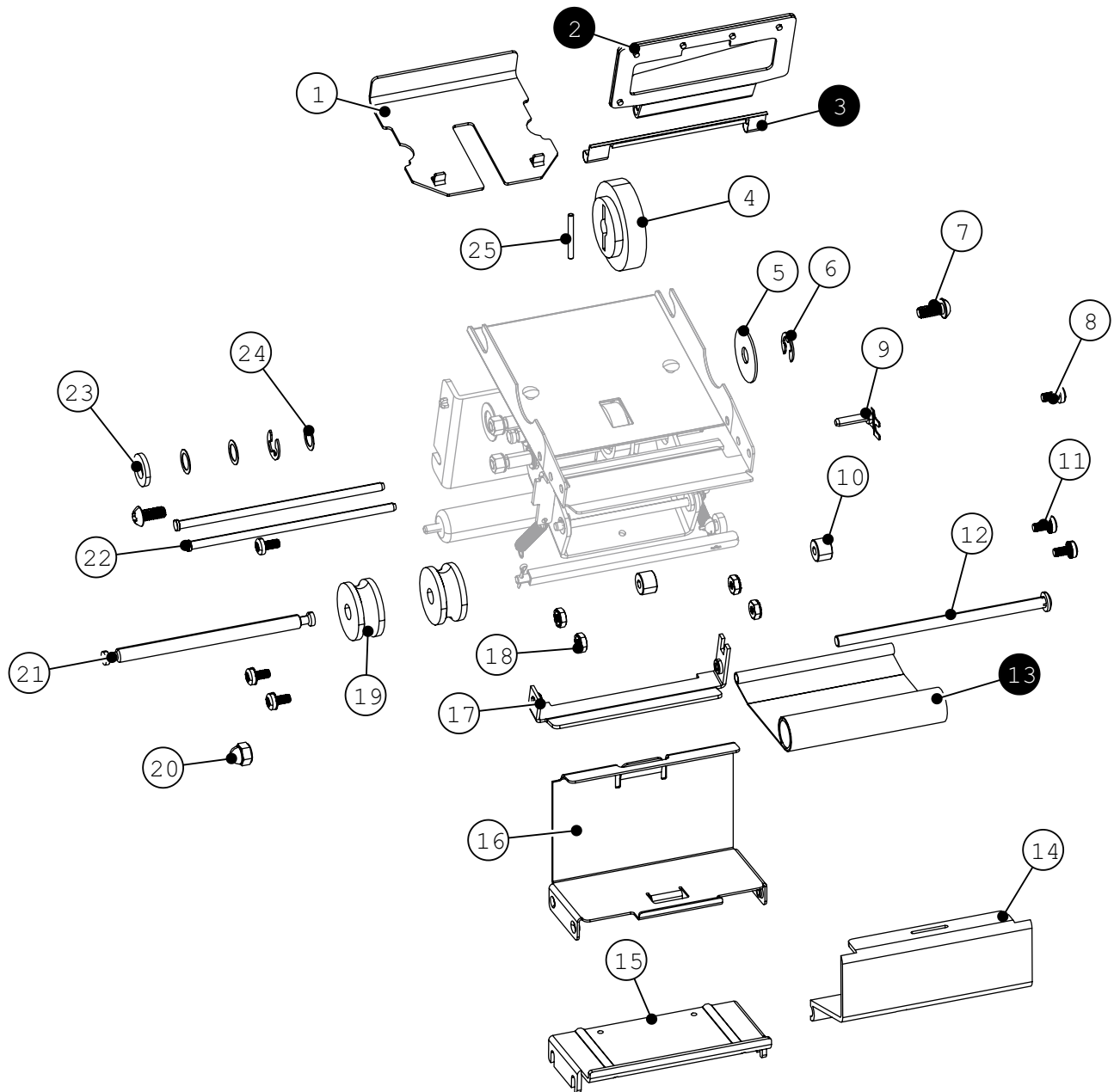

ITEM	PART NUMBER	DESCRIPTION	QTY
1	FM-12EL	UPPER TAPE PLATE	1
2	FM-313	UPPER SHEAR BLADE ASSY	1
3	SA-10-XXK	FELT AND BRACKET KIT	1
4	E555-065-00	FEED WHEEL	1
5	ST-2528	FENDER WASHER	1
6	FM-94-K	RETAINING RING PACK OF 4	2
7	TO-265	1/4-20 x 1/2" PHILIPS	2
8	TO-105	#10-32 x 3/8" PHILIPS PACK OF 2	2
9	TS33-021-01	PRESSURE PLATE PIVOT ASSY	1
10	FM-18-A	SHEAR GUIDE ROLLER	2
11	ST-1949	#10-21 x 3/8" PHILIPS	4
12	FM-61	TIE SCREW	1
13	FM-16-X	PRESSURE PLATE SUB ASSY	1

ITEM	PART NUMBER	DESCRIPTION	QTY
14	FM-3	LOWER FRONT COVER	1
15	FM-40	TANK SHELF GRAY	1
16	TS33-032-01	SAFETY BAFFLE	1
17	FM-130-JX	SUPPORT BRACKET	1
18	ST-2890	#10-24 KEPS NUT	4
19	001-050-0	WOOD SPOOL	2
20	ST-2881	1/4-20 ACORN NUT	1
21	FM-67	PULLEY SHAFT	1
22	FM-15	SUPPORT ROD	2
23	FM-51	WASHER	1
24	K-35-B	WASHER	3
25	EA-46-P	FEED WHEEL PIN	1

APPENDIX

Tape Cutting Assemblies

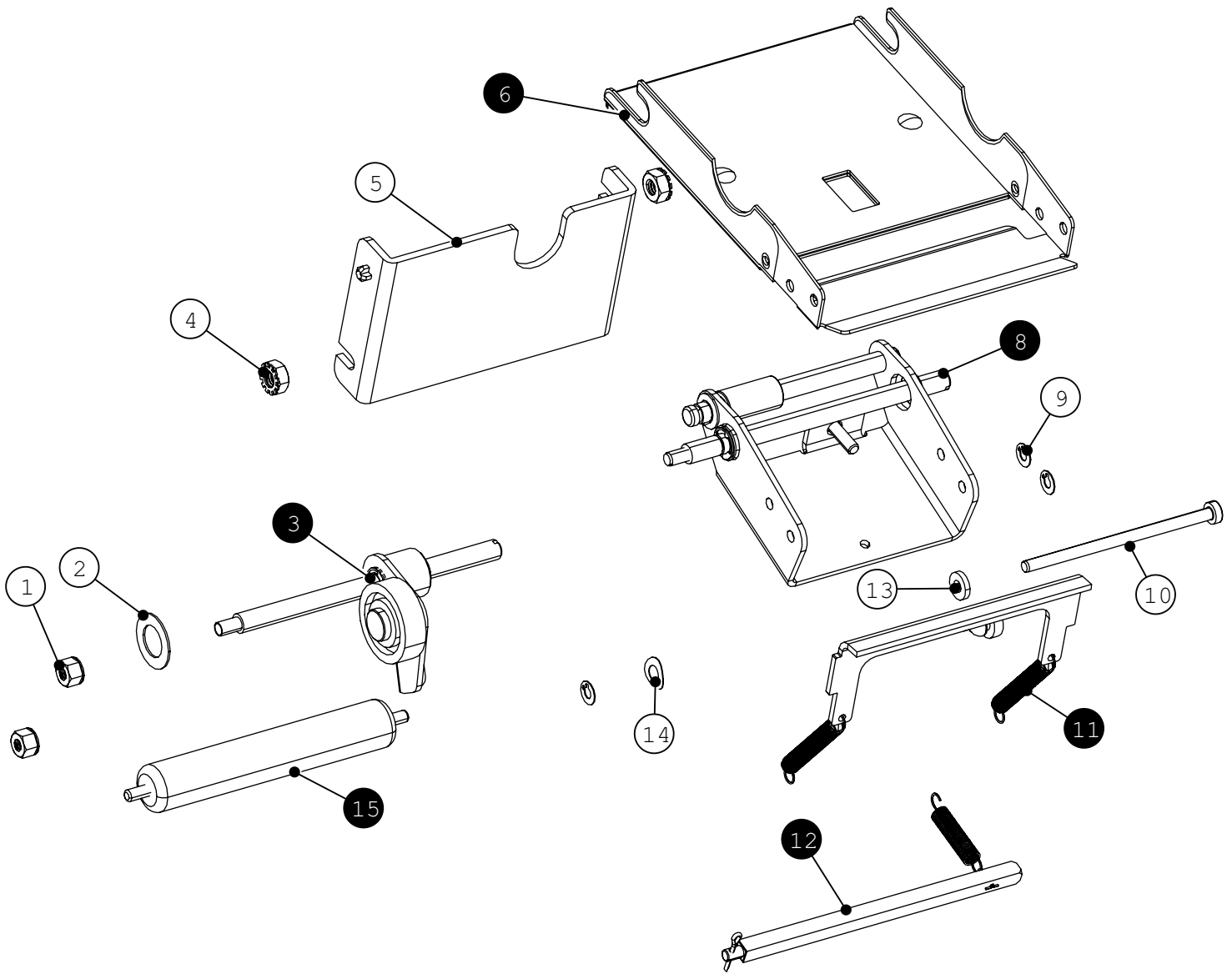

ITEM	PART NUMBER	DESCRIPTION	QTY
1	K-242-AB	#12-24 LOCK NUT	2
2	K-35-A	WASHER PACK OF 2	1
3	FM-39-XXX	IDLER SHAFT SUB ASSY	1
4	ST-2882	1/4-20 KEPS NUT	2
5	FM-58P	VERTICAL TIE PLATE	1
6	FM-11X	LWR TAPE PLATE SUB ASSY	1
8	FM-26-XX	ROCKER SUB ASSY	1
9	WK-21-BS	RETAINING RING	3

ITEM	PART NUMBER	DESCRIPTION	QTY
10	FM-25-C	BLADE PIVOT PIN	1
11	FM-21-X	STATIONARY BLADE ASSY	1
12	FM-108-X	ROCKER STOP BAR SUB ASSY	1
13	FM-14	WASHER	1
14	ST-2895	WAVE WASHER	1
15	FM-59X	TAPE ROLLER ASSY	1

APPENDIX

Handle

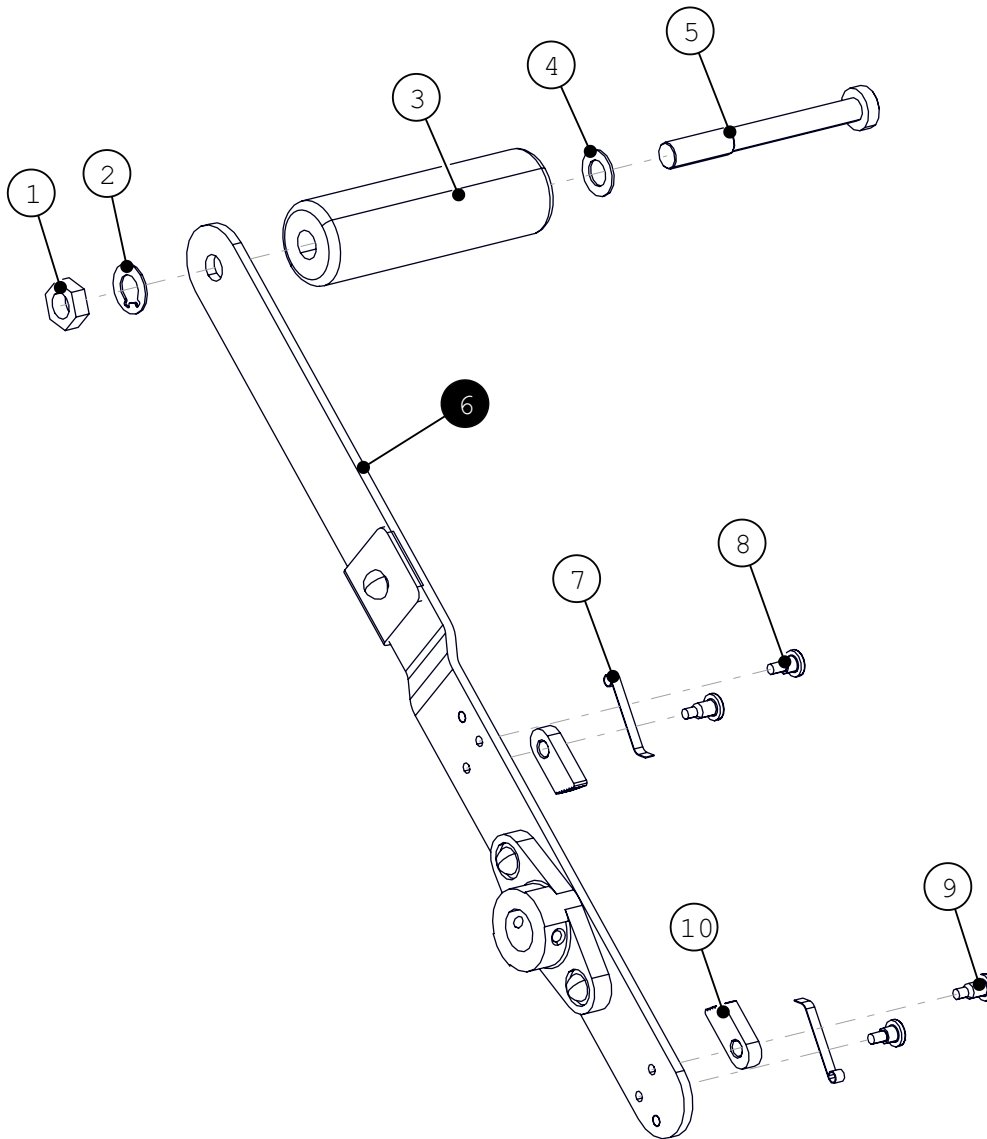

ITEM	PART NUMBER	DESCRIPTION	QTY
1	K-417-A	5/16-18 HEX NUT	1
2	1218SS	5/16 LOCK WASHER	1
3	FM-70	HANDLE	1
4	SX-49-B	9/16 WASHER	1
5	FM-71	HANDLE BOLT	1
6	FM-41-X	HANDLE SUB ASSY	1

ITEM	PART NUMBER	DESCRIPTION	QTY
7	K-45	SPRING	2
8	GE-94	SPRING STUD	2
9	FM-43	PAWL STUD	2
10	K-44-B	PAWL	2

APPENDIX

Part Kits

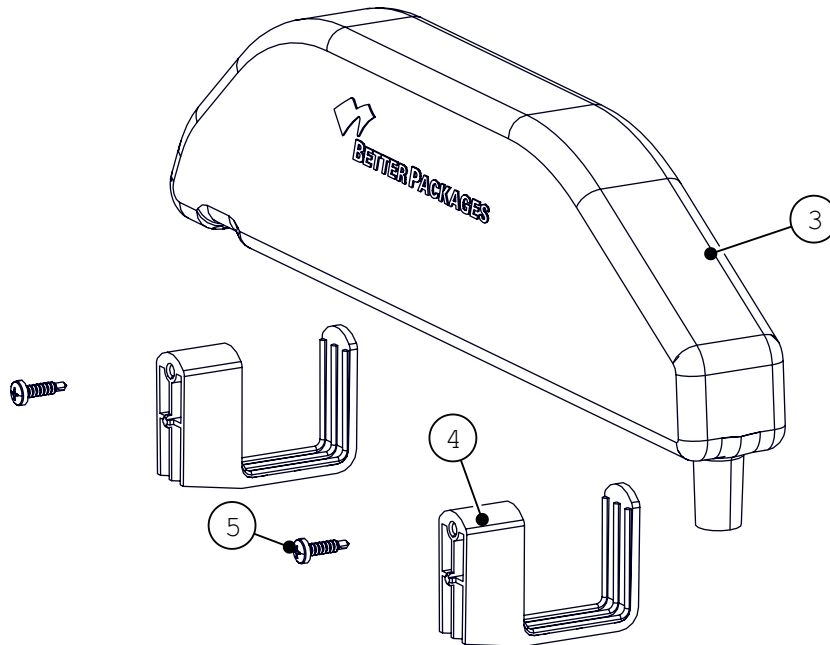
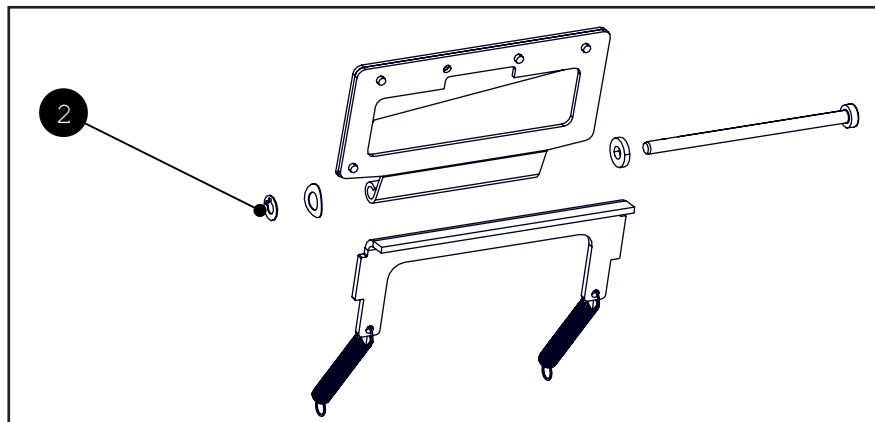
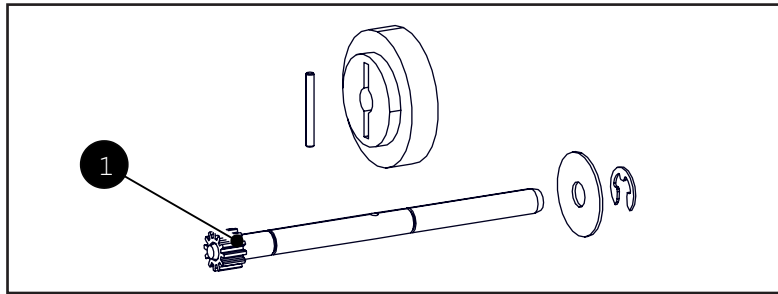

ITEM	PART NUMBER	DESCRIPTION	QTY
1	FM-304-K	FEED WHEEL CONVERSION KIT	1
2	FM-305-K	TAB CUTTER SHEAR BLADE KIT	1
3	FF-610-0	WATER BOTTLE	1
4	FF-612-P	BOTTLE BRACKET	2
5	0237710	#10-16 x 3/4" PHILIPS	2

Early models of the 333, those with a brown color and red serial label, may have a different water bottle. This can be upgraded to the current bottle by purchasing the Philips screws, Bottle Brackets, and Water Bottle. The holes will already exist in the older model.

USER NOTES

